

# 2022 Santa Barbara Presentation

## Field and Virtual Inspections of Solar Photovoltaic and Energy Storage Systems

Bill Brooks  
Brooks Engineering

1

CALBO TRAINING INSTITUTE

### Field Inspection Checklist for Rooftop Photovoltaic (PV) Systems

Make sure all PV system ac/dc disconnects and circuit breakers are in the open position and verify the items that follow in this presentation.

**SHOULD BE "OFF" TO START THE INSPECTION**



2

2

CALBO TRAINING INSTITUTE

### 1. All work done in a neat and workmanlike manner (NEC 110.12)



**NO CONDUCTORS HANGING DOWN  
ATTRACTING ATTENTION OR DEBRIS**



3

3

CALBO TRAINING INSTITUTE

### 1. All work done in a neat and workmanlike manner?? (NEC 110.12)



**UGLY**



**GOOD**

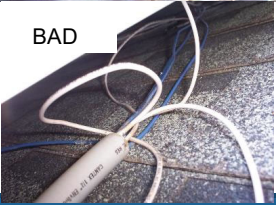

**BAD**

4

4

CALBO TRAINING INSTITUTE

2. PV module model number, quantity and location (also neat and workmanlike).



5

5

CALBO TRAINING INSTITUTE

2. PV module model number, quantity and location.

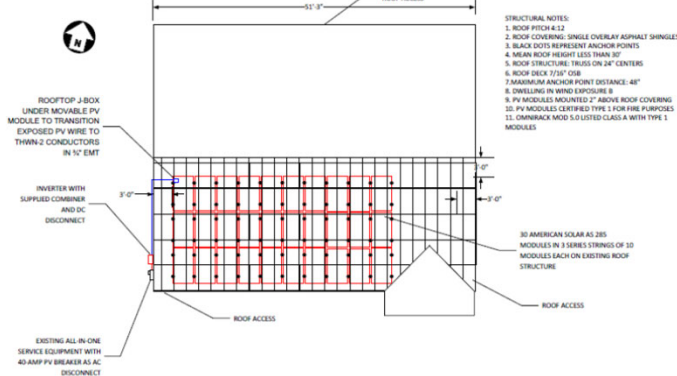

6

6

CALBO TRAINING INSTITUTE

2. PV module model number, quantity and location (bad structurally and aesthetically).



7

7

CALBO TRAINING INSTITUTE



3. Array mounting system and structural connections according to the approved plan.  
4. Roof penetrations flashed/sealed according to the approved plan.

8

8

5. Array exposed cables are properly secured, supported and routed to prevent physical damage.



5. Array exposed cables are properly secured, supported and routed to prevent physical damage.



6. Conduit correctly installed and according to NEC 690.31.



### 2018 IRC PV Setbacks – Section R324

- 1. A min of 2 paths from gutter to ridge for roof with adjacent planes.**
  - One must be on driveway or street side

CALBO TRAINING INSTITUTE

### 7. Firefighter access according to approved plan.

*"Not less than two minimum 36 in. (914 mm) wide pathways on separate roof planes, from lowest roof edge to ridge, shall be provided on all buildings."*

Pathway to Ridge

Street Side

*"For each roof plane with a photovoltaic array, a minimum 36 in. (914 mm) wide pathway from the lowest roof edge to ridge shall be provided on the same roof plane as the photovoltaic array, on an adjacent roof plane, or straddling the same and adjacent roof planes."*

NYS 23-0045-c

13

13

CALBO TRAINING INSTITUTE

### 7. Firefighter access according to approved plan.

ROOF ACCESS

ROOFTOP J-BOX UNDER MOBILE PV MODULE TO TRANSITION EXPOSED PV WIRE TO THIN-WALL CONDUCTORS IN 1" EMT (spaced 3' minimum)

120 AMP AC SUBPANEL WITH TWO 20 AMP PV BREAKERS

EXISTING ALL-IN-ONE SERVICE EQUIPMENT WITH 40 AMP PV BREAKER AC AC DISCONNECT

STRUCTURAL NOTES:

1. ROOF PITCH 4:12
2. ROOF COVERING: SINGLE LAYER ASPHALT SHINGLES
3. BLACK DOTS REPRESENT ANCHOR POINTS
4. MEAN ROOF HEIGHT LESS THAN 30'
5. ROOF STRUCTURE: 2x8 RAFTERS ON 24" CENTERS WITH MIDSPAN SUPPORT—MAX SPAN 11'0"
6. ROOF DECK: 7/16" OSB
7. MAXIMUM ANCHOR POINT HORIZONTAL DISTANCE: 22"
8. DOWELING IN WIND EXPOSURE 8
9. ANCHORS ARE 1/2" LAS SCREWS WITH 2.5" EMBEDMENT IN STRUCTURE
10. BACK ANCHOR FLASHED WITH "ANCHOR FLASH" ALUMINUM FLASHING
11. ALL MODULE RAILS RUN PERPENDICULAR TO RAFTERS
12. PV MODULES MOUNTED 1" ABOVE ROOF COVERING
13. PV MODULES CERTIFIED TYPE I FOR FIRE PURPOSES
14. CHAINBACK MOD 3.0 LISTED CLASS A WITH TYPE I MODULES

30 AMERICAN SOLAR AS 250 MODULES EACH CONNECTED TO AN AMERICAN INVERTER AS 250 MICROINVERTER IN TWO CIRCUITS OF 15 MICROINVERTERS EACH ON EXISTING ROOF STRUCTURE

ROOF ACCESS

14

14

CALBO TRAINING INSTITUTE

**FIRE FIGHTERS HAD PLENTY OF ROOM TO FIGHT THE FIRE AT THIS RESIDENCE**

15

15

CALBO TRAINING INSTITUTE

### 2018 IRC PV Setbacks

#### Section R324

1. A min of 2 paths from gutter to ridge for roof with adjacent planes.
  - One must be on driveway or street side
2. Ridge setback can be 18" in following cases:
  - Total system size is <33% of total roof area
  - Up to 66% when fire sprinklers are installed

16

16

CALBO TRAINING INSTITUTE

### Ridge Setbacks – <33% Total Roof Area

18" Setback from both sides of ridge above PV

NY-13-045-c

17

17

CALBO TRAINING INSTITUTE

### Ridge Setbacks – Sprinkled, <66% Total Roof Area

Adjacent roof can be used for one of the required pathways (if within step height)

18" Setback from Both Sides of Ridge above PV

Pathway to Ridge

18

18

CALBO TRAINING INSTITUTE

### 8. Roof-mounted PV systems have the required fire classification

PHOTOVOLTAIC MODULE	
MODEL	KC120-1
SER. NO.	D1832A1055
DATE	2001.6
POWER	120 W
VOLTS	16.9 V
CURRENT	7.10 A
VOLTS	21.5 V
CURRENT	7.45 A
MAX. SYS. VOLT.	600 V
MAX. CURRENT	11 A
WEIGHT	11.9 kg

**CERTIFICATE OF COMPLIANCE**

UL 2703

UL LISTED

CLASS C

**Certificate of Compliance**

UL 2703

UL LISTED

CLASS C

19

19

CALBO TRAINING INSTITUTE

### 9. Grounding/bonding of rack and modules according to the manufacturer's installation instructions (look for UL2703 listed equipment)

Wrong grounding hardware

Notice slight gap caused by properly installed clip

Hardware consistent with instructions

9. Grounding/bonding of rack and modules according to the manufacturer's installation instructions (look for UL2703 listed equipment)

20

20

CALBO TRAINING INSTITUTE

10. Equipment listed and installed according to the approved plan  
 11. Inverter is marked "interactive."

**PHOTOVOLTAIC MODULE**  
 MODEL: KC120-1  
 SER. NO.: 01632A1055  
 DATE: 2001.6

**Utility Interactive Photovoltaic Inverter**  
 Rated output power: 3200 Watts  
 AC nominal voltage: 240 VAC  
 AC operating limits: 211-264 VAC  
 AC maximum current: 14 Amps  
 AC trip current: 20 Amps  
 AC operating Frequency: 60Hz  
 AC frequency range 59.3-60.5 Hz  
 S/N: SP32240121005343

UL LISTED Utility Interactive Photovoltaic Inverter 20RP

21

21

CALBO TRAINING INSTITUTE

12. Conductors, cables and conduit types, sizes and markings according to the approved plan.

THWN WIRE USED OUTSIDE CONDUIT- NOT ALLOWED

PV WIRE OR USE-2/RHW-2 HAS CORRECT OUTDOOR RATINGS

22

22

CALBO TRAINING INSTITUTE

12. Conductors, cables and conduit types, sizes and markings according to the approved plan.

TAB	DESCRIPTION OR CONDUCTOR TYPE	CONDUIT	NUMBER OF CONDUCTORS	CONDUIT TYPE	CONDUIT SIZE
1	USE-2 or PV WIRE or MFG Cable	MFG	MFG Cable	N/A	N/A
2	EQUIPMENT GROUNDING CONDUCTOR	6 AWG	1 BARE CU	N/A	N/A
3	EXTERIOR CABLE LISTED W/ INV.	MFG	MFG Cable	N/A	N/A
4	THWN-2 or XHHW-2 or RHW-2	12 AWG	2-B, 2-R, 2-W	EMT	1/2"
5	EQUIPMENT GROUNDING CONDUCTOR	12 AWG	1 GREEN	SAME	SAME
6	THWN-2 or XHHW-2 or RHW-2	8 AWG	3-R, 1-B, 1-W	EMT	3/4"
7	EQUIPMENT GROUNDING CONDUCTOR	10 AWG	1 GREEN	SAME	SAME

23

23

CALBO TRAINING INSTITUTE

13. Overcurrent devices are the type and size according to the approved plan

24

24

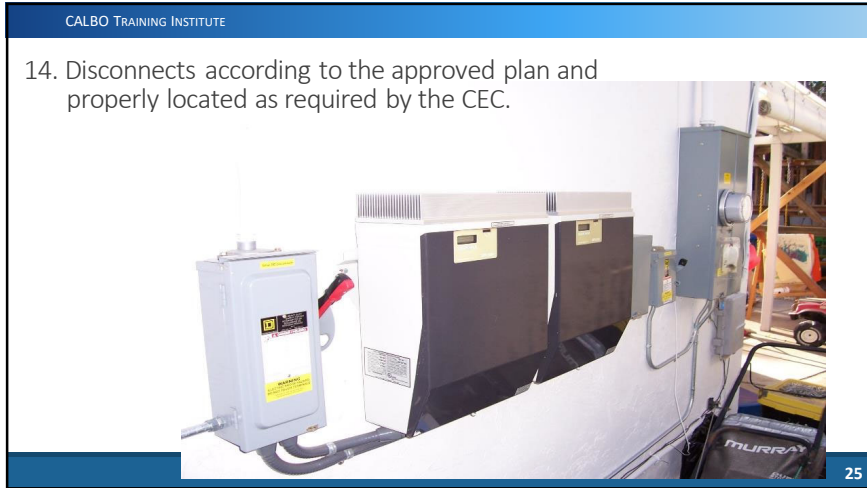

25

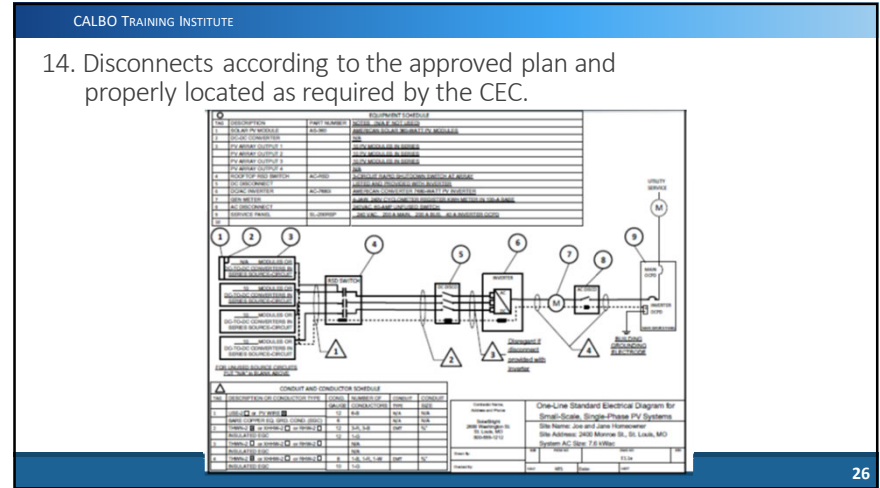

26

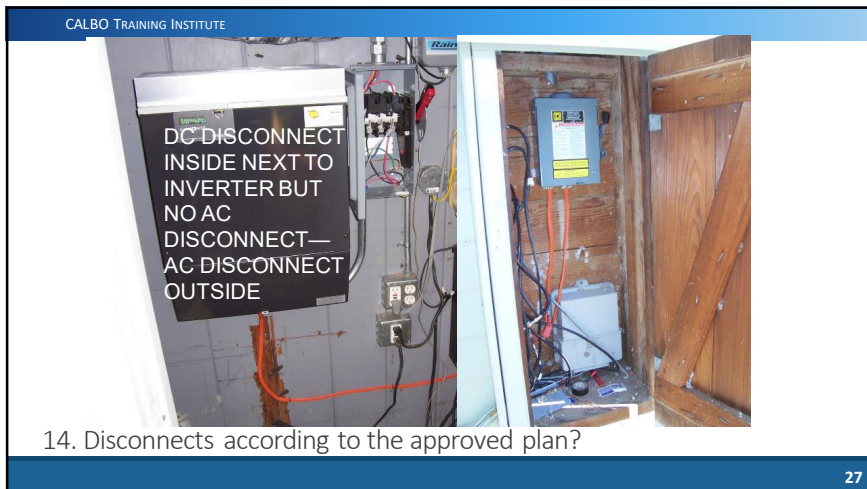

27

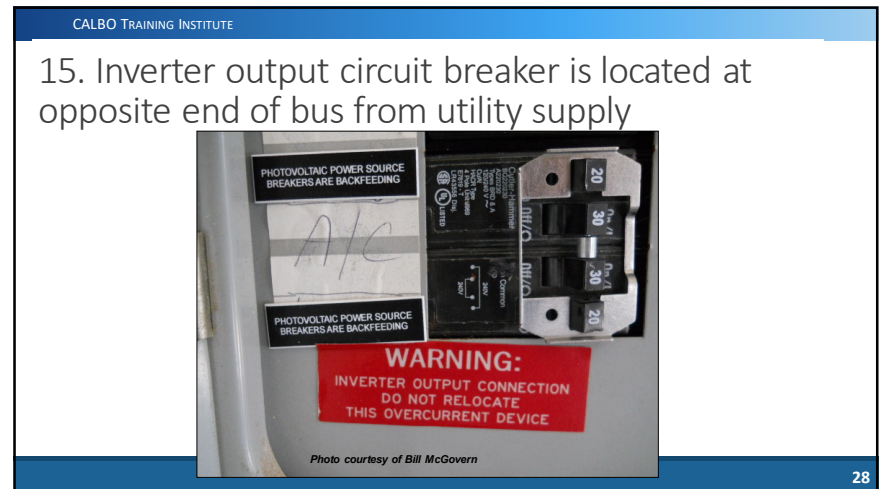

28

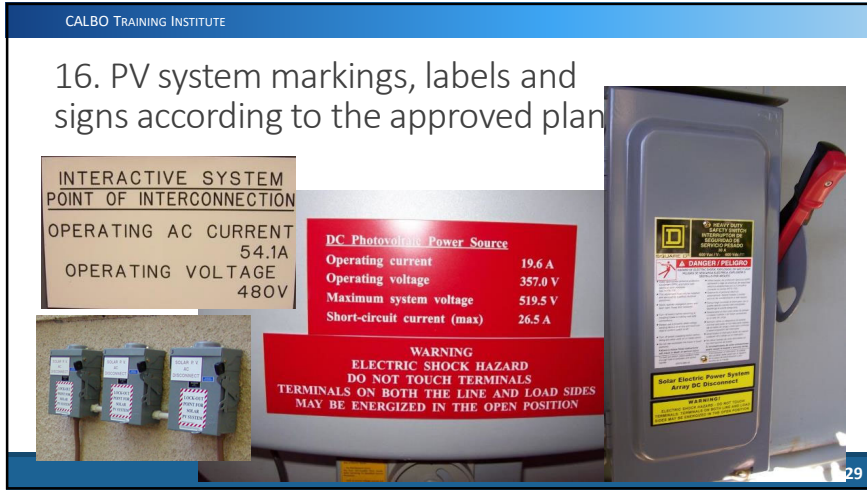

29

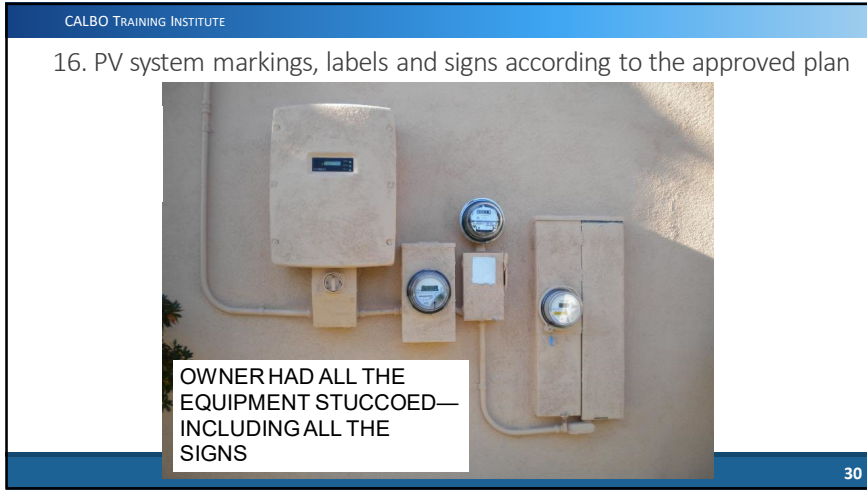

30

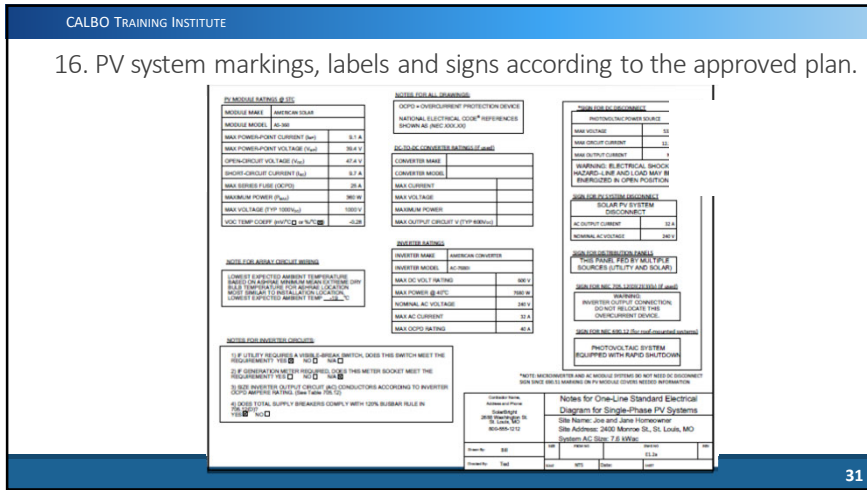

31

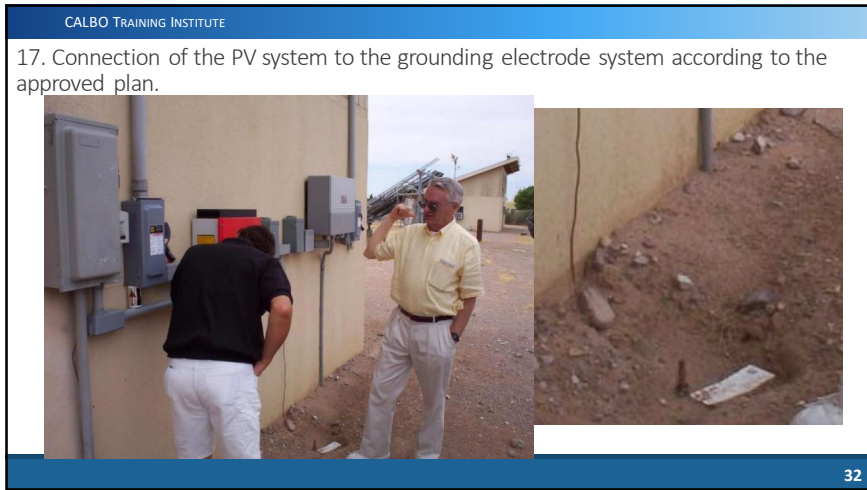

32



## 18. Access and working space for operation and maintenance of PV equipment.



33

33

## 19. The rapid shutdown system is installed according to the approved plan [690.12].

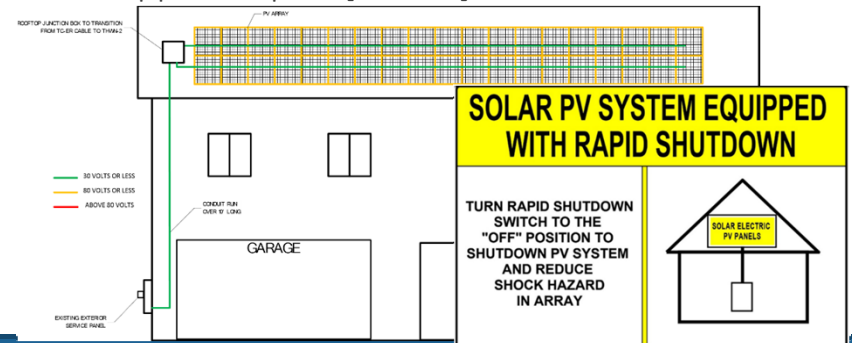

34

34

## Rapid Shutdown in 2019 CEC

- Introduces the new requirements for reduced hazard within the PV array.
- UL 3741, PV Hazard Control, is still under development and there are yet to be any products available under that standard. Lots of good progress.
- 80V limit within the array is most available option for compliance. Dc converters and ac modules work as well as module shutoffs.
- Some companies are developing products to meet the non-metallic option.

35

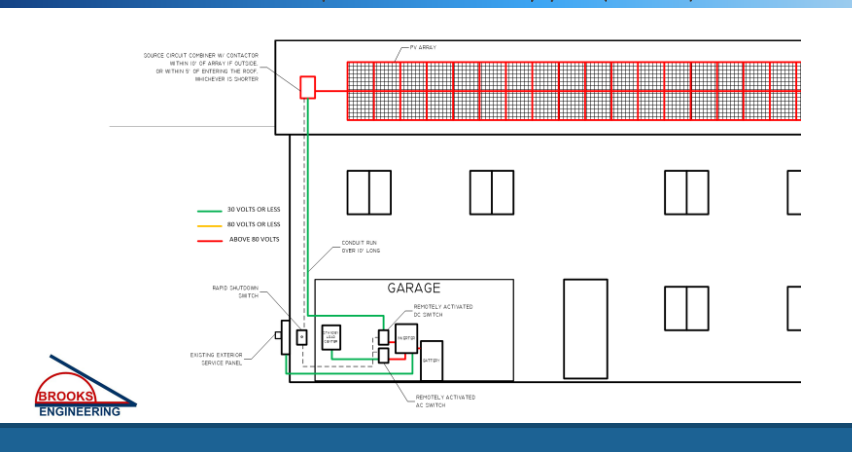

36

CALBO TRAINING INSTITUTE

690.56(C) Buildings with Rapid Shutdown  
For PV systems that shutdown the array and conductors leaving the array

**SOLAR PV SYSTEM EQUIPPED WITH RAPID SHUTDOWN**

TURN RAPID SHUTDOWN SWITCH TO THE "OFF" POSITION TO SHUTDOWN PV SYSTEM AND REDUCE SHOCK HAZARD IN ARRAY

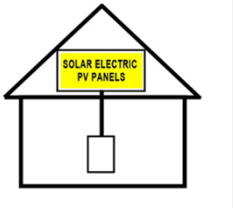

37

CALBO TRAINING INSTITUTE

690.56(C) Buildings with Rapid Shutdown  
For buildings with both types of PV systems

**SOLAR PV SYSTEM EQUIPPED WITH RAPID SHUTDOWN**  
AREAS WITHIN DOTTED LINES REMAIN ENERGIZED IN SUNLIGHT WHEN RAPID SHUTDOWN SWITCH IS IN "OFF" POSITION

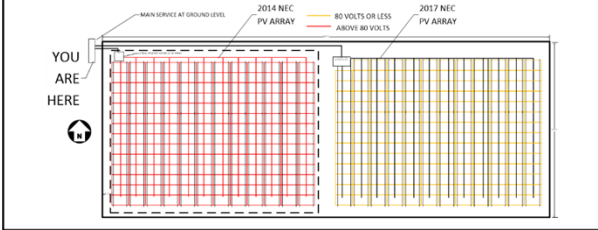

38

CALBO TRAINING INSTITUTE

690.56(C) Buildings with Rapid Shutdown (2019 CEC but still works on current systems)

A rapid shutdown switch shall have a label located on or no more than 1 meter (3 ft) from the switch that includes the following

**RAPID SHUTDOWN SWITCH FOR SOLAR PV SYSTEM**

39

CALBO TRAINING INSTITUTE

2019 CEC 690.12 Rapid Shutdown  
Current Compliance Options

1. String inverters with dc-to-dc converters or shutoff switching devices at each module.
2. Micro-inverters that segment each module (1-4 PV modules per inverter)
3. New UL3741 PV Hazard Control systems
4. Building-Integrated PV array with no exposed metal or wiring and installed more than 8' from grounded metal.

40

## Equipment is available for 2019 CEC version of rapid shutdown

Standard is in place to certify rapid shutdown equipment.

- Existing rapid shutdown listed equipment that is connected directly to PV modules can meet the requirements of the 2019 CEC.
- In addition to using listed rapid shutdown equipment, the certification standard for PV Hazard Control is now available. Several products will be certified to this new listing by the end of 2021.

41

# 705.12 LOAD SIDE SOURCE CONNECTIONS

PRESENTED BY:  
BILL BROOKS

42

## (3) (2) 120% option



(2) Where two sources, one a primary...source and...another power source, are located at opposite ends of a busbar that contains loads, the sum of ...the power source(s)...and the rating of the overcurrent device protecting the busbar shall not exceed 120 percent of the ampacity of the busbar.

The busbar shall be sized for the loads connected in accordance with Article 220.

A permanent warning label shall be applied to the distribution equipment adjacent to the back-fed breaker from the power source that displays the following or equivalent wording:

- WARNING: POWER SOURCE OUTPUT CONNECTION—DO NOT RELOCATE THIS OVERCURRENT DEVICE.

43

## 705.12(3)(2)

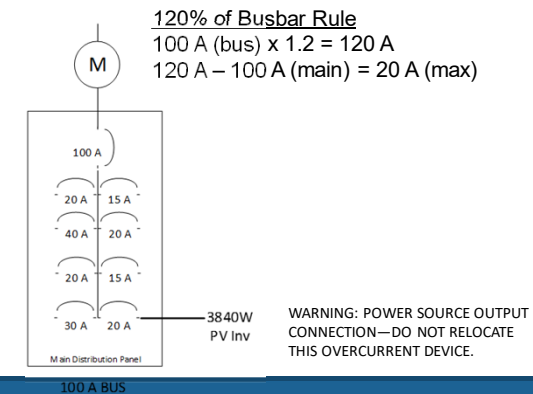

44

CALBO TRAINING INSTITUTE

### (3)(3) Sum of branch breakers used to protect busbar



(3) The sum of the ampere ratings of all overcurrent devices on panelboards, both load and supply devices, excluding the rating of the overcurrent device protecting the busbar, shall not exceed the ampacity of the busbar.

The rating of the overcurrent device protecting the busbar shall not exceed the rating of the busbar.

45

CALBO TRAINING INSTITUTE

### Sum of Breakers Option

200 A (bus) = 30A+30A+30A+40A+40A (either load or supply)

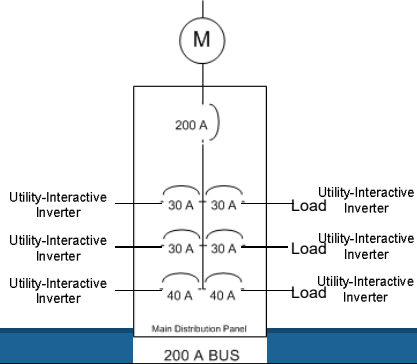

46

CALBO TRAINING INSTITUTE

### Modified Hawaiian Tie-In Example

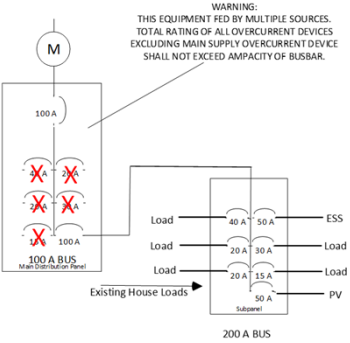

WARNING: THIS EQUIPMENT FED BY MULTIPLE SOURCES. TOTAL RATING OF ALL OVERCURRENT DEVICES EXCLUDING MAIN SUPPLY OVERCURRENT DEVICE SHALL NOT EXCEED AMPACITY OF BUSBAR.

47

CALBO TRAINING INSTITUTE

### (3)(4) center-fed panelboards

(4) A connection at either end of a center-fed panelboard in dwellings shall be permitted where the sum of 125 percent of the power source(s) output circuit current and the rating of the overcurrent device protecting the busbar does not exceed 120 percent of the current rating of the busbar.

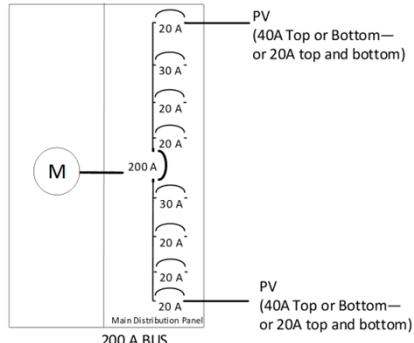

48

CALBO TRAINING INSTITUTE

### (5) Engineering supervision option

(5) Connections shall be permitted on switchgear, switchboards, and panelboards in configurations other than those permitted in 705.12(B)(3)(1) through (B)(3)(4) where designed under engineering supervision that includes available fault current and busbar load calculations.

49

CALBO TRAINING INSTITUTE

### 705.12(C) Marking. 705.12(D) Suitable for Backfeed.

(C) **Marking.** Equipment containing overcurrent devices in circuits supplying power to a busbar or conductor supplied from multiple sources shall be marked to indicate the presence of all sources.

(D) **Suitable for Backfeed.** Fused disconnects, unless otherwise marked, shall be considered suitable for backfeed. Circuit breakers not marked “line” and “load” shall be considered suitable for backfeed. Circuit breakers marked “line” and “load” shall be considered suitable for backfeed or reverse current if specifically rated.

50

CALBO TRAINING INSTITUTE

### 705.12 (E) Fastening

(E) **Fastening.** Listed plug-in-type circuit breakers backed from electric power sources that are listed and identified as interactive shall be permitted to omit the additional fastener normally required by 408.36(D) for such applications.

51

CALBO TRAINING INSTITUTE

### Energy Storage System configurations—dc coupled

Dc coupled multimode system

52

## Retrofit of Existing PV systems will be commonplace



53

## System configurations—ac coupled

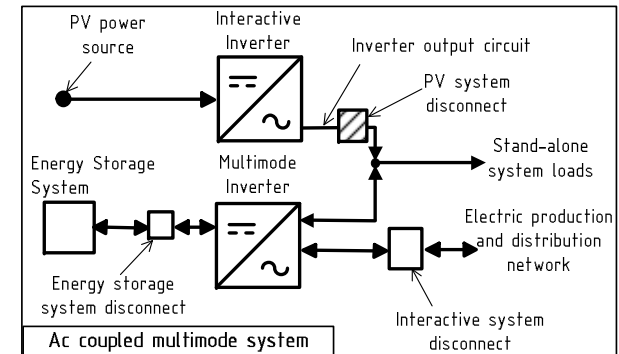

54

## July 2021 CRC ESS Changes

### SECTION R327 ENERGY STORAGE SYSTEMS

**R327.1 General.** ~~Stationary storage battery systems~~ Energy Storage Systems (ESS) shall comply with the provisions of this section.

#### **Exceptions:**

1. ESS listed and labeled in accordance with UL 9540 and marked "For use in residential dwelling units", where installed in accordance with the manufacturer's instructions and NFPA 70.
2. ESS less than 1 kWh (3.6 megajoules).

55

## July 2021 CRC ESS Changes

**R327.2 Equipment listings.** ESS shall be listed and labeled ~~for residential use~~ in accordance with UL 9540.

#### **Exceptions**

- ~~1.~~ Where approved, repurposed unlisted battery systems from electric vehicles are allowed to be installed outdoors or in detached sheds located not less than 5 feet (1524 mm) from exterior walls, property lines and public ways.
- ~~2.~~ Battery systems that are an integral part of an electric vehicle are allowed provided that the installation complies with Section 625.48 of NFPA 70.
- ~~3.~~ Battery systems less than 1 kWh (3.6 megajoules).

56

## July 2021 CRC ESS Changes

**R327.3 Installation.** ESS shall be installed in accordance with the manufacturer's instructions and their listing, ~~if applicable, and shall not be installed within the habitable space of a dwelling unit.~~

**Add new text as follows:**

### **R327.3.1 Spacing**

Individual units shall be separated from each other by at least three feet (914 mm) of spacing unless smaller separation distances are documented to be adequate based on large scale fire testing complying with Section 1206.1.5 of the International Fire Code.

57

## July 2021 CRC ESS Changes

### **R327.4 Locations.**

ESS shall only be installed in the following locations:

1. Detached garages and detached accessory structures.
2. Attached garages separated from the dwelling unit living space in accordance with Section R302.6
3. Outdoors or on the exterior side of exterior walls located a minimum 3 feet (914 mm) from doors and windows directly entering the dwelling unit.

58

## July 2021 CRC ESS Changes

### **R327.4 Locations (cont).**

4. Enclosed utility closets, basements, storage or utility spaces within dwelling units with finished or noncombustible walls and ceilings. Walls and ceilings of unfinished wood-framed construction shall be provided with minimum 5/8 in. Type X gypsum. ESS shall not be installed in sleeping rooms, or closets or spaces opening directly into sleeping rooms.

59

Where?

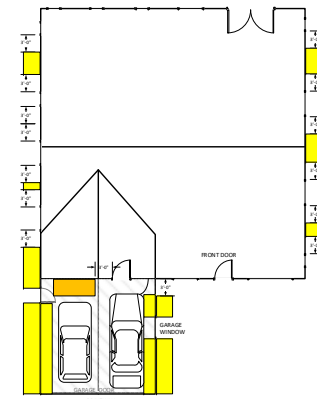

60

## July 2021 CRC ESS Changes

### **R327.5 Energy ratings.**

Individual ESS units shall have a maximum rating of 20 kWh. The aggregate rating of the ESS shall not exceed:

1. 40 kWh within utility closets, basements, and storage or utility spaces.
2. 80 kWh in attached or detached garages and detached accessory structures.
3. 80 kWh on exterior walls.
4. 80 kWh outdoors on the ground. ESS installations exceeding the permitted individual or aggregate ratings shall be installed in accordance with Section 1206.1 through 1206.9 of the International Fire Code.

61

## July 2021 CRC ESS Changes

### **Add new text as follows:**

#### **R327.7 Fire detection.**

Rooms and areas within dwellings units, basements, and attached garages in which ESS are installed shall be protected by smoke alarms in accordance with Section R314. A heat detector listed and interconnected to the smoke alarms shall be installed in locations within dwelling units and attached garages where smoke alarms cannot be installed based on their listing.

62

## July 2021 CRC ESS Changes

**R327.8** ~~**R327.6**~~ **Protection from impact.** Stationary storage battery systems ESS installed in a location subject to vehicle damage shall be protected by approved barriers.

**R327.9** ~~**R327.5**~~ **Ventilation.** Indoor installations of stationary storage battery systems ESS that include batteries that produce hydrogen or other flammable gases during charging shall be provided with mechanical ventilation in accordance with Section M1307.4.

63

## July 2021 CRC ESS Changes

#### **R327.10 Electric vehicle use.**

The temporary use of an owner or occupant's electric powered vehicle to power a dwelling unit while parked in an attached or detached garage or outside shall comply with the vehicle manufacturer's instructions and NFPA 70.

64



## Field Inspection Checklist for Energy Storage Systems (ESS)

Make sure all ESS ac/dc disconnects and circuit breakers are in the open position and verify the items that follow in this presentation.

**SHOULD BE "OFF" TO START THE INSPECTION**

65

65

## UL 9540

1. ESS is installed according to manufacturer's installation instructions for the UL9540 listing.



66

66

## Meets Size Limits

2. The individual ESS storage units are no larger than 20 kWh. Units installed meet one of the size and location limitations shown in items (3) and (4) below.



67

67

## Spacing of ESS Units

3. The individual ESS storage units are installed separated by 36" or are installed in accordance with approved large-scale fire testing results (UL 9540a or equivalent approved tests).

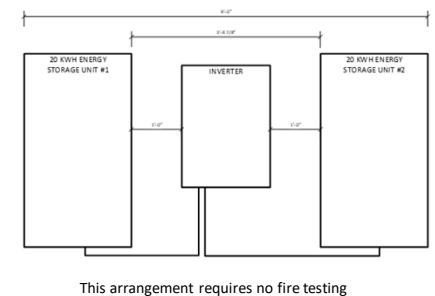

68

68

CALBO TRAINING INSTITUTE

### Spacing of ESS Units

3. The individual ESS storage units are installed are separated by 36" or are installed in accordance with approved large-scale fire testing results (UL 9540a or equivalent approved tests).

This arrangement requires fire testing to show that 12" spacing is acceptable.

69

69

CALBO TRAINING INSTITUTE

### Spacing of ESS Units

This arrangement requires no fire testing

70

70

CALBO TRAINING INSTITUTE

### Spacing of ESS Units

This arrangement requires fire testing to show that 12" spacing is acceptable. Takes up 4' less of wall space.

71

71

CALBO TRAINING INSTITUTE

### Capacity and Location of ESS Units

4. Each ESS meet one of the size and location limitations:

- a.) 80 kWh in attached garages separated from the dwelling unit living space in accordance with Section R302.6.

72

72

CALBO TRAINING INSTITUTE

### Capacity and Location of ESS Units

4. Each ESS meet one of the size and location limitations:  
 b.) 80 kWh on exterior walls a minimum 3 feet (914 mm) from doors and windows directly entering the dwelling unit (garage doors and windows do not enter the dwelling unit).

73

73

CALBO TRAINING INSTITUTE

### Capacity and Location of ESS Units

4. Each ESS meet one of the size and location limitations:  
 c. 40 kWh within utility closets, basements, and storage or utility spaces with finished or noncombustible walls and ceilings. Walls and ceilings of unfinished wood-framed construction shall be provided with minimum 5/8 in. Type X gypsum.

74

74

CALBO TRAINING INSTITUTE

### Capacity and Location of ESS Units

4. Each ESS meet one of the size and location limitations:  
 d.) 80 kWh in detached garages and detached accessory structures.

75

75

CALBO TRAINING INSTITUTE

### Capacity and Location of ESS Units

4. Each ESS meet one of the size and location limitations:  
 e. 80 kWh outdoors on the ground a minimum 3 feet (914 mm) from doors and windows directly entering the dwelling unit.

76

76

## Protection from Vehicle Damage of ESS Units

### 5. Vehicle Impact Protection Recommendations

- a.) Do not install ESS on exterior of building where driveway is paved to the building exterior (18"-24" space between driveway and building is a reasonable minimum)
- b.) Install ESS on side walls of interior of garage.
- c.) Install ESS above 48" on end wall of garage.
- d.) If ESS installed below 48" on end wall of garage, use a parking curb 3' from front of ESS to prevent vehicle damage.

77

77

## Protection from Vehicle Damage of ESS Units

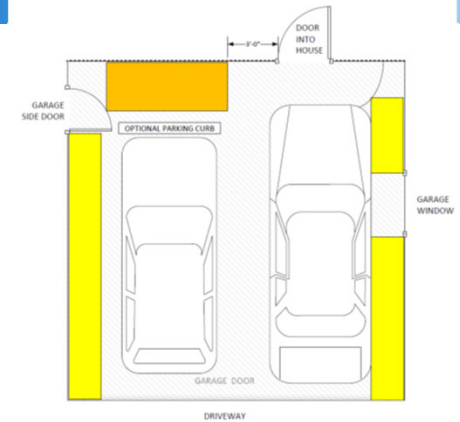

78

78

## Article 706 Highlights

### "706.7 Disconnecting Means."

(A) ESS Disconnecting Means. A disconnecting means shall be provided for all ungrounded conductors derived from an ESS. A disconnecting means shall be readily accessible and located within sight of the ESS.

79

## Article 706 Highlights

### "706.7 Disconnecting Means." (2&3 not required for dwellings)

(D) Notification. The disconnecting means shall be legibly marked in the field. The marking shall meet the requirements of 110.21(B) and shall include the following:

- (1) Nominal ESS voltage
- (2) Maximum available short-circuit current derived from the ESS
- (3) The associated clearing time or arc duration based on the available short-circuit current from the ESS and associated overcurrent protective devices if applicable

80

## Article 706 Highlights

“706.30 Installation of Batteries.

(A) Dwelling Units. An ESS for dwelling units shall not exceed 100 volts between conductors or to ground.

Exception: Where live parts are not accessible during routine ESS maintenance, an ESS voltage exceeding 100 volts shall be permitted.”

UL9540 precludes exposed live parts so there is NO limitation on voltage within the ESS in the NEC—the limits are in UL9540.

81

## Code and Stds Rapidly Developing

- UL9540 is still a new standard (several certified so far—mostly with Intertek)
- NFPA 855: *Standard for the Installation of Stationary Energy Storage Systems* is published.
- Interconnection standards will evolve with PV+Storage systems.
- The 2020 NEC and future IFC and IBC revisions will continue to evolve the safety standards.

82

## A lot has changed in 15 years



- Codes and standards are rapidly changing.
- New certification processes will help improve safety and design.
- Need to make room for existing and advanced lead-acid technologies.

83

Questions?

Bill Brooks, Brooks Engineering

[bill@brooksolar.com](mailto:bill@brooksolar.com)

84