



# We will be starting soon!

*Thanks for joining us*



# 2022 Energy Code for Non-Residential



*Jennifer Rennick – In Balance Green Consulting*  
*Grant Murphy– In Balance Green Consulting*

May 17, 2023





# Zoom Orientation

- Please be sure your full name is displayed
- Please **mute** upon joining
- Use "Chat" box to share questions or comments
- Under "Participant" select "Raise Hand" to share a question or comment verbally
- The session may be **recorded** and posted to 3C-REN's on-demand page. Feel free to ask questions via the chat and keep video off if you want to remain anonymous in the recording.

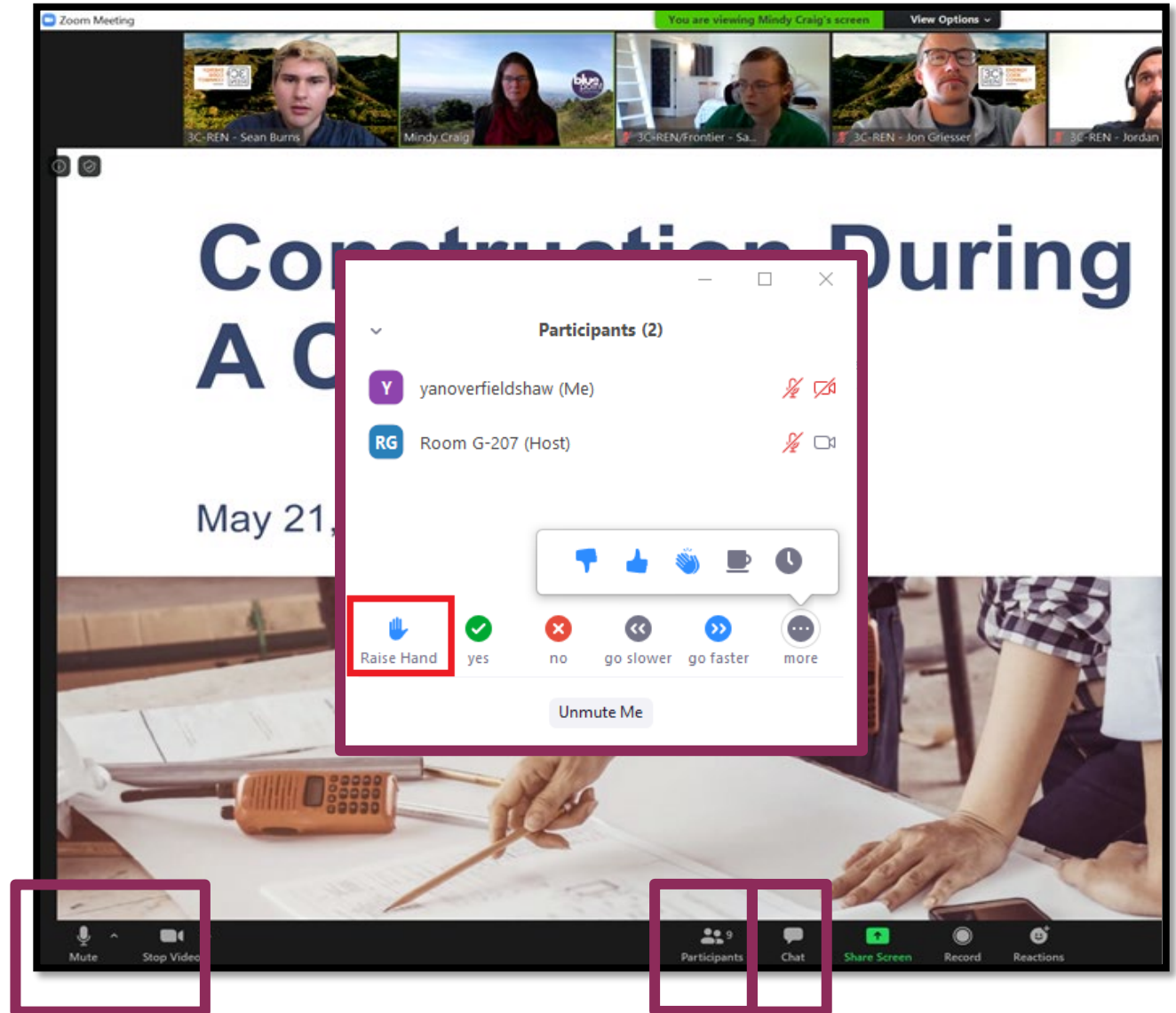

# 3C-REN: Tri-County Regional Energy Network

- Three counties working together to improve energy efficiency in the region
- Services for –
  - **Building Professionals:** industry events, training, and energy code compliance support
  - **Households:** free and discounted home upgrades
- Funded by ratepayer dollars that 3C-REN returns to the region

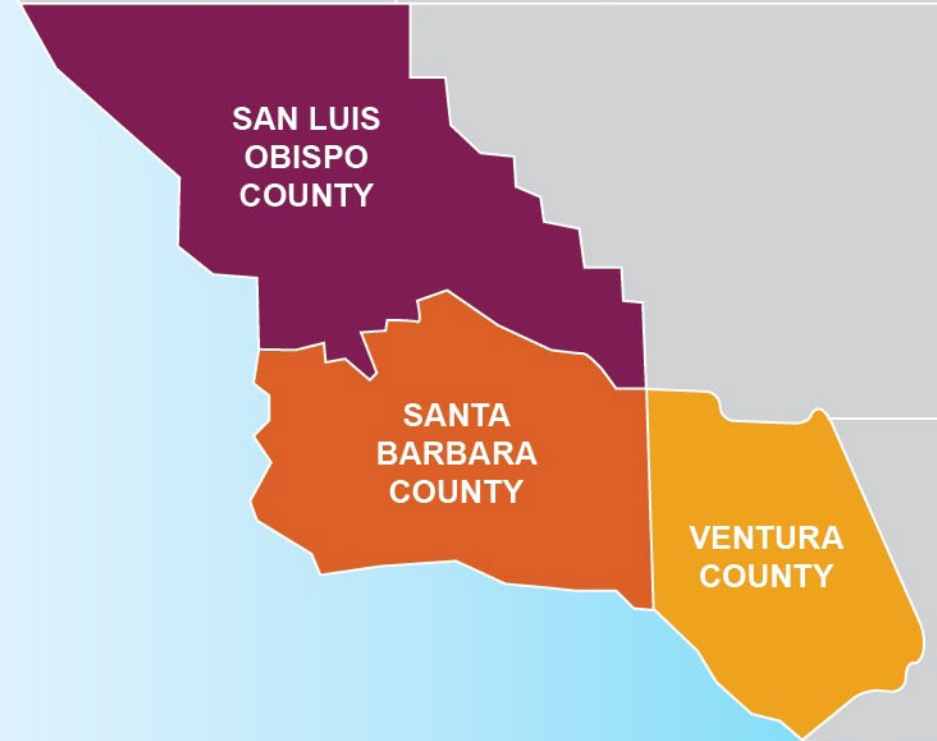



ENERGY  
CODE  
CONNECT

- Serves all building professionals
- Provided services –
  - **Energy Code Coach**
  - **Training and Support**
  - **Reach Code Support**
  - **Regional Forums**
- Makes the Energy Code easy to follow

Energy Code Coach:  
[3c-ren.org/codes](https://3c-ren.org/codes)

Event Registration:  
[3c-ren.org/events](https://3c-ren.org/events)







## BUILDING PERFORMANCE TRAINING

- Serves current and prospective building professionals
- Expert instruction:
  - **Technical skills**
  - **Soft skills**
- Helps workers to thrive in an evolving industry

Event Registration:  
[3c-ren.org/events](https://3c-ren.org/events)





HOME  
ENERGY  
SAVINGS

### Multifamily (5+ units)

- No cost technical assistance
- Rebates up to \$750/apartment plus additional rebates for specialty measures like heat pumps

### Single Family (up to 4 units)

- Sign up to participate!
- Get paid for the metered energy savings of your customers

Enrollment:  
[3C-REN.org/contractor-participation](https://3C-REN.org/contractor-participation)





# 2022 Energy Code and CAL Green Training Series

JAN 12 - 2022 ENERGY CODE: SINGLE FAMILY

FEB 7 - 2022 ENERGY CODE: EXISTING BUILDINGS,  
ADDITIONS, AND ALTERATIONS (SINGLE FAMILY)

MAR 8 - 2022 ENERGY CODE: ACCESSORY  
DWELLING UNITS (ADUS)

APR 6 - 2022 ENERGY CODE: MULTIFAMILY  
PROJECTS

MAY 4 - 2022 CAL GREEN: RES & NON-RES

**MAY 17 - 2022 ENERGY CODE: NONRESIDENTIAL**



<https://www.3c-ren.org/calendar-of-events-and-trainings/>



# Today's Learning Objectives

- Learn how the 2022 Energy Code has been reorganized
- Review high level changes that have been made to the 2022 Energy Code impacting nonresidential and hotel/motel building projects.
- Learn some of the specific changes have been made to the 2022 Energy Code for nonresidential and hotel/motel building projects:
  - Mandatory Measures
  - Performance and Prescriptive
  - Additions and Alterations





# Energy Code Triennial Cycle





# California Energy Commission (CEC)

## Our Responsibilities

- Advancing State Energy Policy
- Achieving Energy Efficiency
- Investing in Energy Innovation
- Developing Renewable Energy
- Transforming Transportation
- Overseeing Energy Infrastructure
- Preparing for Energy Emergencies

EXPLORE OUR CORE RESPONSIBILITIES >



California's Building Energy Efficiency Standards (aka the Energy Code) is updated every three years the by CEC. The process includes engagement with the public, industry experts, in-house expertise, and other stakeholders.

### ABOUT

The California Energy Commission is leading the state to a 100 percent clean energy future. As the state's primary energy policy and planning agency, the Energy Commission is committed to reducing energy costs and environmental impacts of energy use while ensuring a safe, resilient, and reliable supply of energy.

[About the Energy Commission](#)  
[CEC's 45th Anniversary Events](#)

[energy.ca.gov](http://energy.ca.gov)

### DIVISIONS

- Efficiency
- Energy Assessments
- Energy Research and Development
- Fuels and Transportation
- Renewable Energy
- Siting, Transmission, and Environmental Protection

### LEADERSHIP



**Gavin Newsom**  
California Governor



**Wade Crowfoot**  
Secretary for Natural Resources



**David Hochschild**  
Chair, California Energy Commission



# Big Picture Goals for the 2022 Code Updates

HOMES AND BUSINESSES USE  
NEARLY **70 PERCENT**  
OF CALIFORNIA'S ELECTRICITY AND  
ARE RESPONSIBLE FOR A QUARTER  
OF CALIFORNIA'S GREENHOUSE  
GAS (GHG) EMISSIONS.



- Encourage heat pump technology for space and water heating
- Establish electric-ready requirements for single family and multifamily projects
- Expand PV systems and battery storage standards
- Strengthen ventilation standards





# Focus on 3C-REN Tri-County Region

San Luis Obispo, Santa  
Barbara, and Ventura

CZ's: 4, 5, 6, 9, and 16

Under the Building Energy Efficiency  
Standards California has 16 defined  
Climate Zones (CZ)

To find yours search "California EZ  
Building Climate Zone Search Tool"

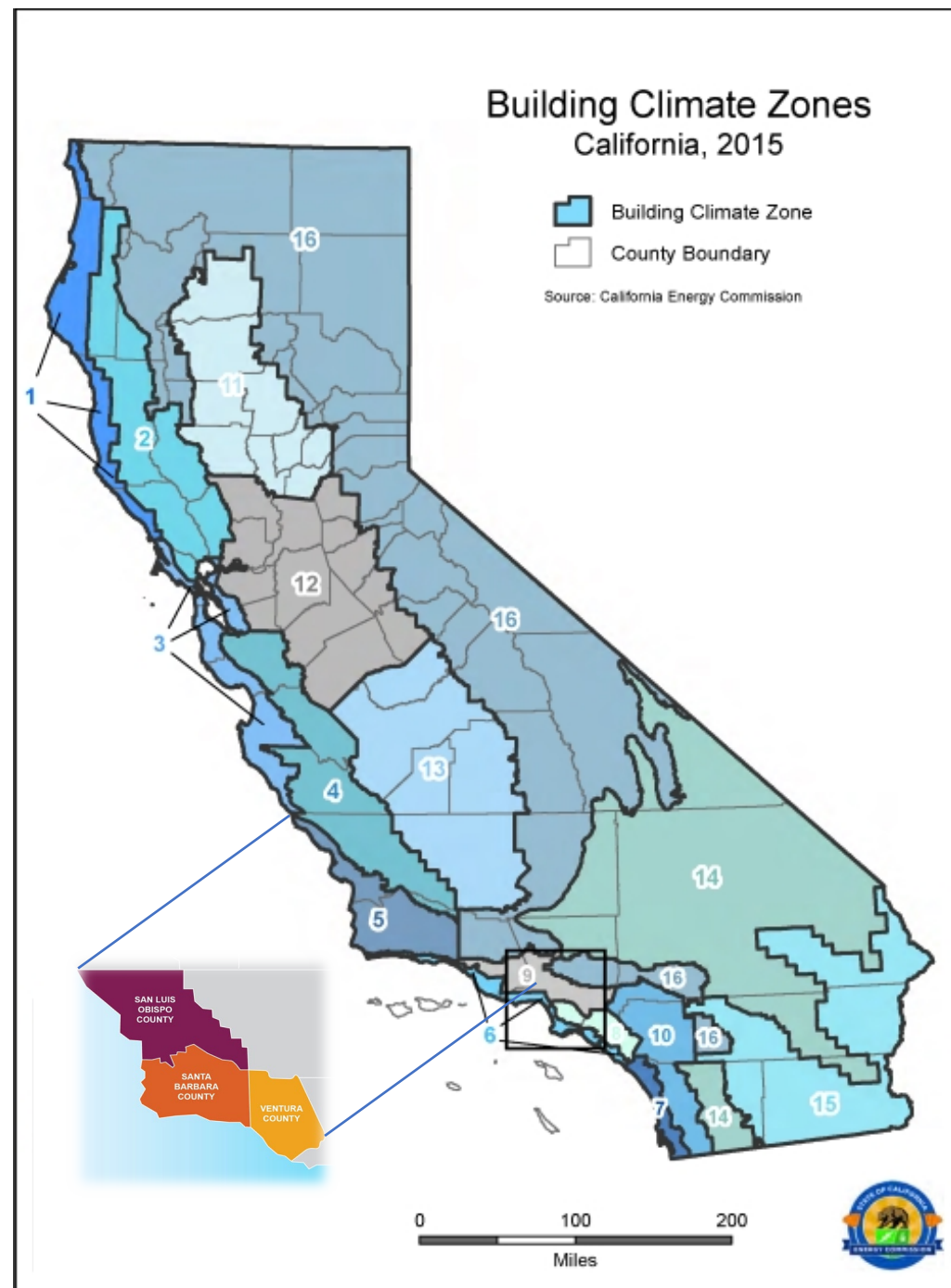

# What You Need to Know

## 2022 Building Code went into affect January 1, 2023

- Project that **apply for permit** on or after January 1, 2023 will fall under the 2022 Code
- Documents available at: <https://www.energy.ca.gov/programs-and-topics/programs/building-energy-efficiency-standards/2022-building-energy-efficiency>



# Energy Code Connect – Title 24 Services – Resource Library

<https://www.3c-ren.org/energy-code-connect>



CONTRACTORS  
& INDUSTRY

MULTIFAMILY  
PROPERTIES

FOR  
RESIDENTS



## ENERGY CODE CONNECT

Energy Code Connect makes it easier for building professionals to use, comply with, and enforce California's complex and ever-changing energy code.

### SERVICES



**Energy Code Coach**

Personalized support for building professionals navigating the Energy Code/Title 24



**Regional Forums**

Quarterly events to learn how the energy code relates to critical policy issues in our region



**Events & Trainings**

Free courses to help you understand and apply energy code and green building standards



**Reach Code Support**

Technical expertise and implementation support to expand electrification in your jurisdiction



**Resource Library**

Documents and reference forms for CalGreen and California Energy codes

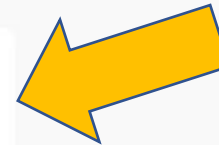



# Energy Code Re-organization

Multifamily Highrise Removed from Non-Res Sections  
Separate Multifamily Subchapters Added

# Subchapter Reorganization

## 2019 Code

All Buildings -Sections 100 and 110

High-Rise Residential, Nonresidential, Hotel/Motel -Sections 120, 130, 140, and 141

Low-Rise Residential -Section 150.0-150.2

## 2022 Code

All Buildings -Sections 100 and 110

Nonresidential, Hotel/Motel -Sections 120, 130, 140, and 141

Single-Family Residential -Section 150.0-150.2 (includes duplexes and townhouses)

**New Sections**

Multifamily Buildings -Sections 160, 170, 180 (low and high rise)



# T24 Part 6 Energy Code – Subchapter Organization



All [regulated] Occupancies  
(A, B, E, F, H, I M, R, S, or U, except I-3 and I-4)

**Subchapter 1** –All Occupancy –Scope, Definition  
**Subchapter 2** –All Occupancies – Mandatory Requirements

Sec 100.0-100.3  
&  
Sec 110.0-110.12

*Not* Low-Rise Res

Low-Rise Res

**Subchapter 3** –Nonresidential, High-Rise Res, Hotel/Motel, Covered Process –Mandatory Requirements  
[HVAC and Ventilation]

Sec 120.0-120.9

**Subchapter 4** –Nonresidential, High-Rise Res, Hotel/Motel – Mandatory Requirements  
[Lighting and Power]

Sec 130.0-130.5

**Subchapter 7** –Low-Rise Residential Mandatory Measures

Sec 150.0

**Subchapter 5** –Performance and Prescriptive  
[New Construction]

Sec 140.0-140.9

**Subchapter 6** – Additions and Alterations

Sec 141.0-141.1

**Subchapter 8** – Performance and Prescriptive  
[New Construction]

Sec 150.1

**Subchapter 9** – Additions and Alterations

Sec 150.2

# T24 Part 6 Energy Code – Subchapter Organization

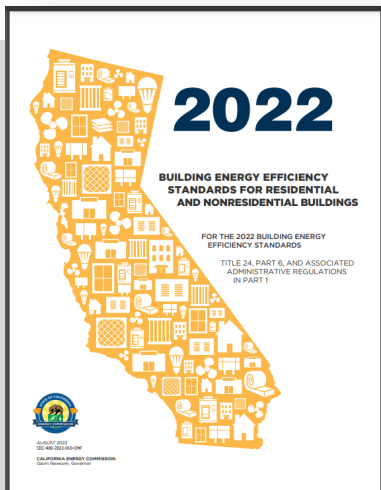

All [regulated] Occupancies  
(A, B, E, F, H, I M, R, S, or U, except I-3 and I-4)

**Subchapter 1** –All Occupancy –Scope, Definitions  
**Subchapter 2** –All Occupancies – Mandatory Requirements

Sec 100.0-100.3  
&  
Sec 110.0-110.12

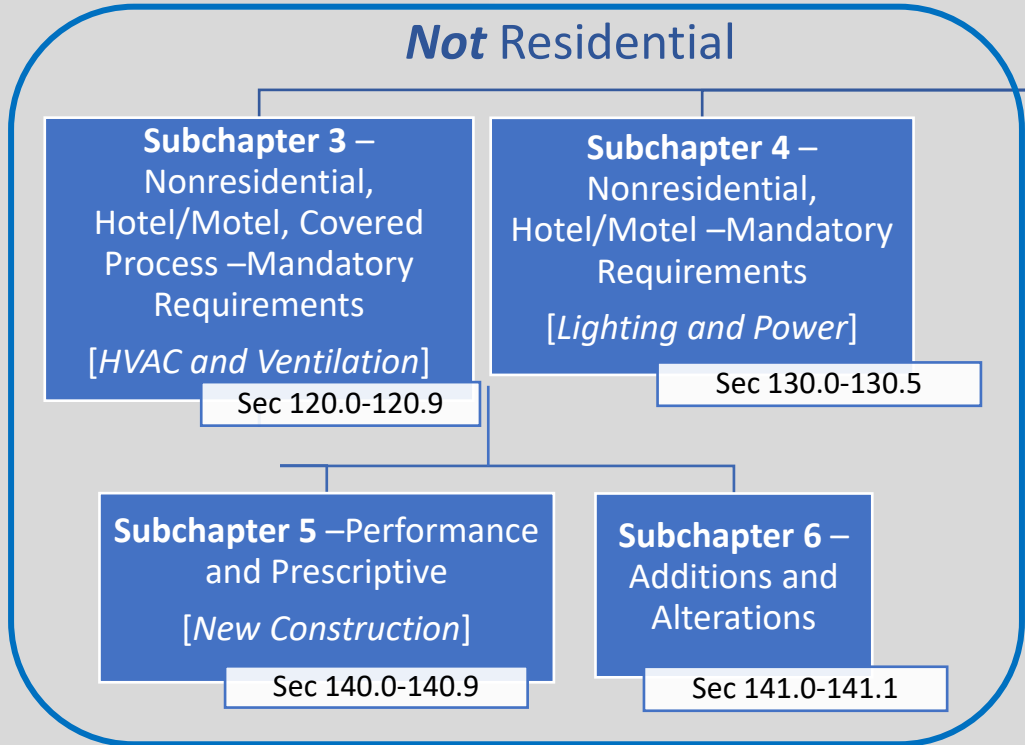

## Single Family Res

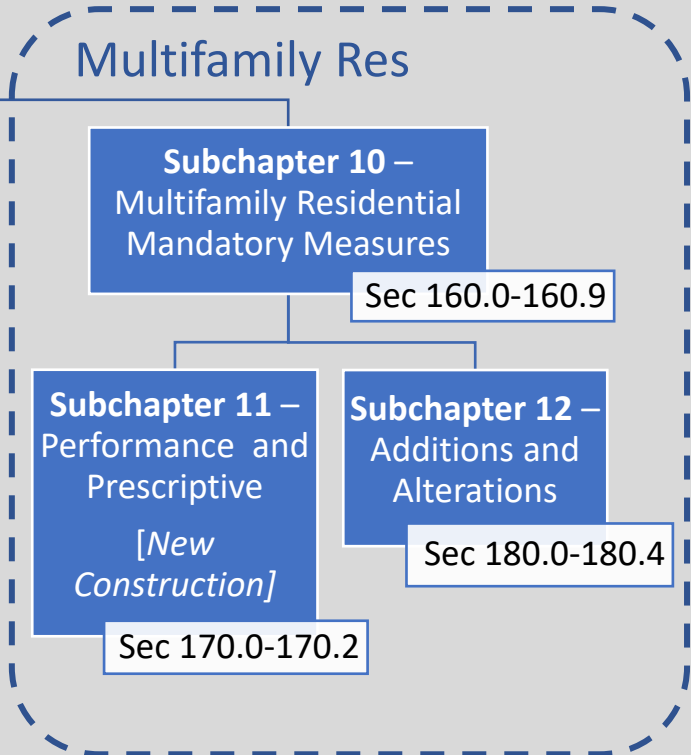
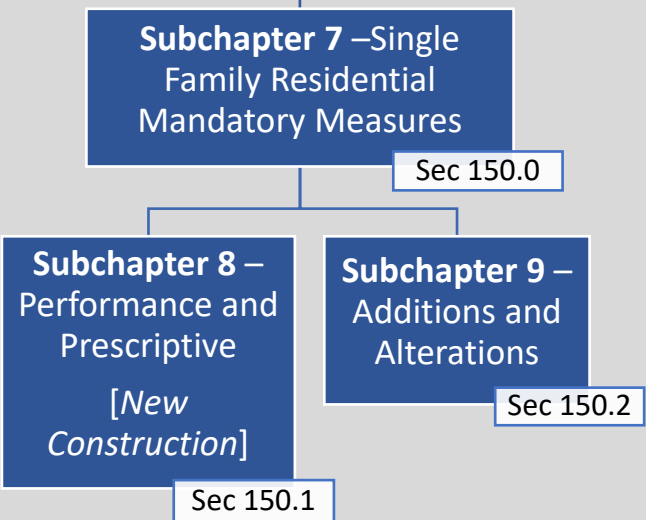



# Nonresidential Changes

Review High Level Changes  
Review Compliance Pathways



# Non-Residential High-Level Changes

- Envelope and Fenestration
- HVAC –Heating System, Fans, and Outside Air Ventilation
- Lighting –Indoor and Outdoor
- Covered Processes
- Photovoltaic (PV) and Battery Systems
- Reminder: Includes Hotel/Motel. Some of the code language specifies whether it applies to Guest Rooms only or to the Nonresidential spaces in general

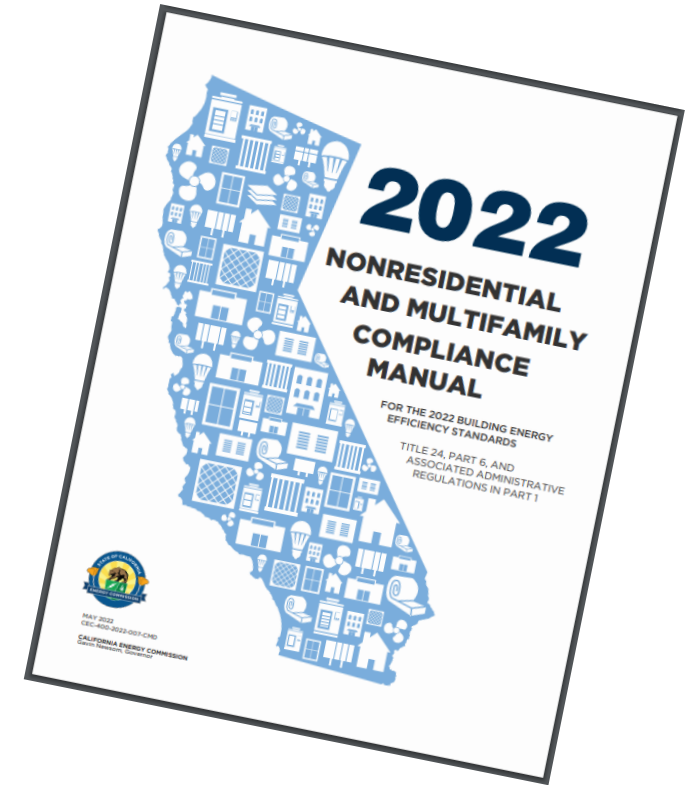

# The Energy Code –Three Compliance Terms

## Mandatory Requirements

Energy efficiency measures that are applicable to all projects.

### Prescriptive Component Package

Mandatory Requirements are applicable

Follow all the parts of the prescriptive package

Note: used to determine the Standard Design Building

Essentially a **checklist** approach

### Performance Method

Mandatory Requirements are applicable

Other components or measures can be traded-off as long as the Proposed Design Building can be shown to be more energy efficiency than a similar sized Standard Design Building (baseline building)

**Energy modeling** approach

# Performance Metrics (Computer Modeling)

Compliance is demonstrated via regulated energy:

- Space Heating and Cooling
- Ventilation
- Water Heating
- Indoor Lighting
- **Solar PV**
- **Battery Storage**
- Covered Process Loads

Compliance software has changes to the **Standard Design** which now **varies by climate zone** and includes **heat pumps**

**Community shared solar electric and/or battery system** is allowable with specific requirements. See EXCEPTION Section 140.1(b)





# Performance Method (Computer Modeling)

## Two Metric Types:

- **Source Energy Budget** is the efficiency of the energy used by the building (site energy) as well the energy used to produce, procure, and distribute it from a particular source. It serves as **proxy for carbon-based metric**.
- **TDV Energy Budget** is the efficiency of the building's source energy and brings in TDV multipliers based on when the energy is being used to reflect the actual cost, supply, and demand. It serves to **encourage better performance during peak hours**.

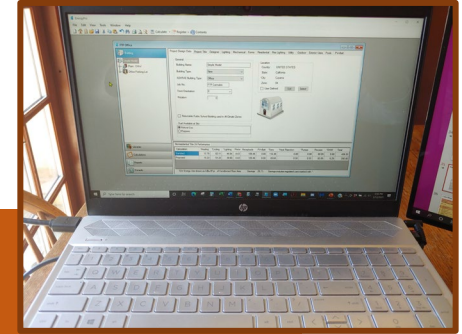

### Key Changes:

- **Solar Electric PV and Battery Storage** Systems were **added** to TDV-Total
- **Source Energy** metric **added** to Performance Compliance



**TDV ENERGY**

Time Dependent Valuation (TDV) Energy values energy use differently based on WHEN the savings occur to encourage better performance during periods of high energy cost,

**TDV continues to be the metric for both 'Efficiency' and 'Total' TDV**

**SITE ENERGY**

Site Energy is the energy consumed in the operation of the building used by the customer.



Primary Source Energy: the energy produced on-site

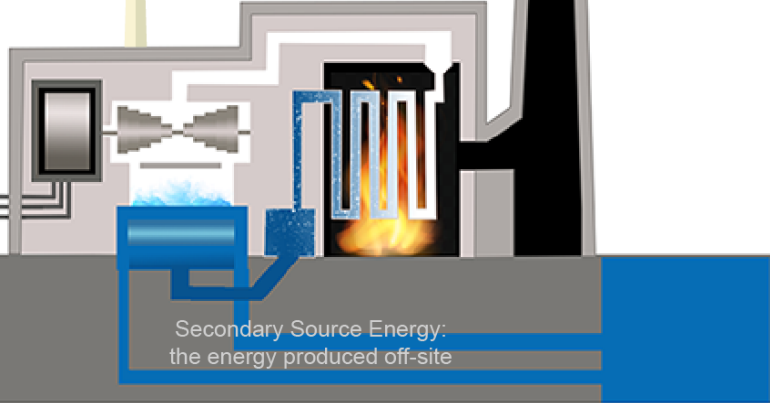
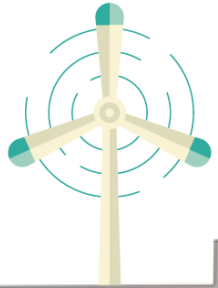

Secondary Source Energy: the energy produced off-site

**SOURCE ENERGY**

Source Energy looks at the energy required to produce, procure, and distribute the energy used by the building to understand its total carbon consumption.

**Source Energy is being used as a proxy for Carbon in New Construction**



# Example Office Building Project Results

CBECC-com 2022

Overall Result <sup>3</sup> :	Efficiency TDV	Total TDV	Source Energy
<b>COMPLIES</b> (not current)			
Standard Design	134.03	12.73	6.13
Proposed Design	131.10	1.06	5.66
Compliance Margins	<b>2.93</b> Pass	<b>11.67</b> Pass	<b>0.47</b> Pass

<sup>1</sup> Efficiency measures include improvements like a better building envelope and more efficient equipment

<sup>2</sup> Compliance Totals include efficiency, photovoltaics and batteries

<sup>3</sup> Building complies when all efficiency and total compliance margins are greater than or equal to zero and unmet load hour limits are not exceeded

Standard Design PV Capacity: 167.9 kWdc / Battery System Capacity: 296.8 kWh (power 70.50 kW)



# Mandatory Measures

Overview of Equipment Efficiencies (All Occupancies)

Sections 120.0 - 130.5

Minor changes to Envelope and Lighting

Significant changes to HVAC and Controls

New Sections for Indoor Horticulture and Computer Rooms



# Change for All Occupancies



Updated equipment efficiencies

Although it applies to all occupancies, the changes will most likely affect non-residential spaces for heating and cooling for medium to large capacity systems.



## Increased HVAC Efficiencies:

- Various cooling systems
- Cooling towers
- Furnaces
- Boilers (starting 1/10/23)

## New tables for:

- Dedicated Outdoor Air Systems (DOAS)
- Computer room units
- Heat pump and heat recovery chillers



Heat Pump with Waste Heat Recovery



Dedicated Outdoor Air System (DOAS)



# Fenestration

NFRC certification of fenestration products and exterior doors other than field-fabricated

For U-factor, SHGC, and VT:

- NA6 formula can only be used for skylights  $\leq 200 \text{ ft}^2$

Note: NA6 formula is no longer valid for vertical fenestration



## Key Take Away:

Nearly all projects will be using **NFRC** rated windows through out the building.



# Demand Response Lighting and Controlled Receptacles

## (c) Lighting Demand Response Controls

**New** – Lighting systems of total installed lighting power of **4,000 watts** or greater (subject to Sec 130.1(b)) --**prior threshold was 10,000 sf**

## (e) Controlled Receptacles

**Receptacles** must be connected to the **demand response** system if the building is required to have demand controlled lighting (subject to Sec 130.1(b))

- Except where health or life safety statute/ordinance/regulation does not allow for demand response

**Reminder: Section 130.1(b)** covers the mandatory controls for indoor lighting where **multilevel controls are required**

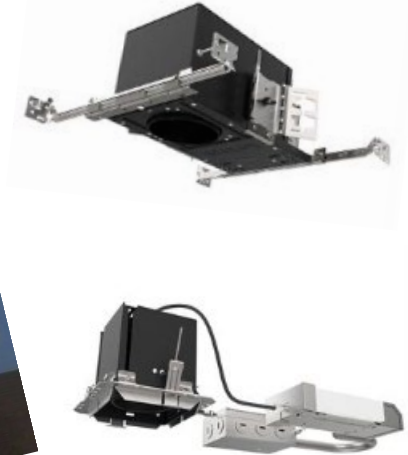

Demand control response shall reduce the lighting power by 15% or greater



# Indoor Lighting Controls

## (a) Manual Area Controls

- Included language that specifies that **scene controllers** can be used if at least one scene turns on general lighting only, and the control provides a means to manually turn off all lighting
- Changed the exemption for **egress illumination to 0.1 watts/sf allowable** for continuous illumination (*previously 0.2 w/sf were allowable*)

## (c) Shut-OFF Controls

- New requirements for offices > 250 ft<sup>2</sup>

## (d) Automatic Daylighting Controls

- Automatic daylighting controls are NOW mandatory in secondary daylit zones

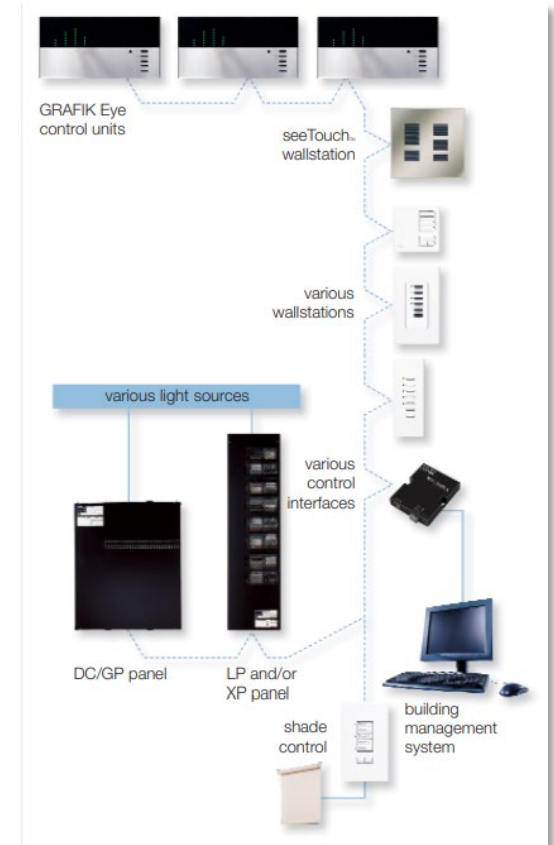

Example of Lutron Controls



# HVAC Ventilation

- Ventilation rate based on Equation 120.1-F based on min ventilation rate and occupiable square footage
  - Alternate method based on occupants for spaces with fixed seating or subject to CBC 1004.5
- Design and control requirements for quantities of outdoor air:
  - Variable air volume (VAV) systems to be capable of maintaining measured outside air rates within 10% of designed minimum
  - **ALL** mechanical ventilation and space conditioning systems are to be tested to confirm they operate within 10% of the designed minimum outside air rate

## Key Update:

Capabiliy and testing had only applied to constant volume systems under the previous code (2019) cycle.



# Duct Leakage Testing

**New duct systems** meeting the following must be **HERS** tested to verify no more than **6% leakage**:

- Provides conditioned air to an occupiable space for a constant volume, single zone space conditioning system
- Serves <5,000 ft<sup>2</sup> of CFA
- Have more than 25% of ducts in unconditioned space or outdoors

Exemptions:

- Healthcare facilities
- New duct systems not subject to testing under Section 120.4(g)1 shall instead meet the duct leakage testing requirements of CMC 603.10.1

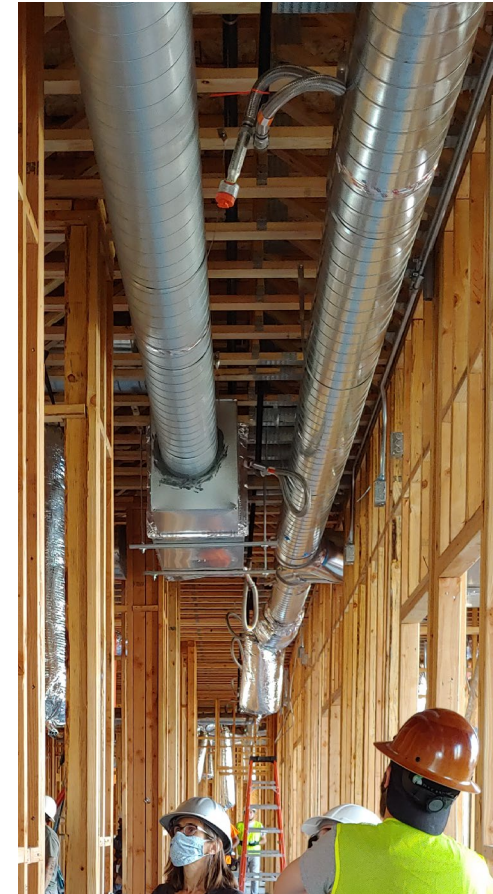

## Key Update:

Duct leakage was a previously a Prescriptive component under the prior code (2019) cycle, but now it is a Mandatory measure.



# Process Boilers, Compressed Air, and Steam Traps

- Boilers:
  - Requirements apply to newly installed process boilers with input capacity  $> 5,000,000$  Btu/hr (was  $> 10,000,000$  Btu/hr)
- Compressed Air:
  - New monitoring, testing, and pipe sizing requirements (Defined by hp or pip length)
- Steam Traps
  - New default diagnostics and other efficiency requirements when operating pressure is  $> 15$  psig and total combined connected boiler input rating is  $> 5,000,000$  Btu/hr

## Key Take Away:

Code is addressing cost effective ways to prevent energy loss from boilers, potentially non-functional steam traps, and failed compress air systems.



# Computer Rooms

## New HVAC controls and efficiencies:

- Reheat controls shall prevent reheating, recooling, and simultaneous heating
- Humidification shall be adiabatic
- Variable fan controls when mechanical cooling capacity > 60,000 BTU/hr and limits on fan motor demand

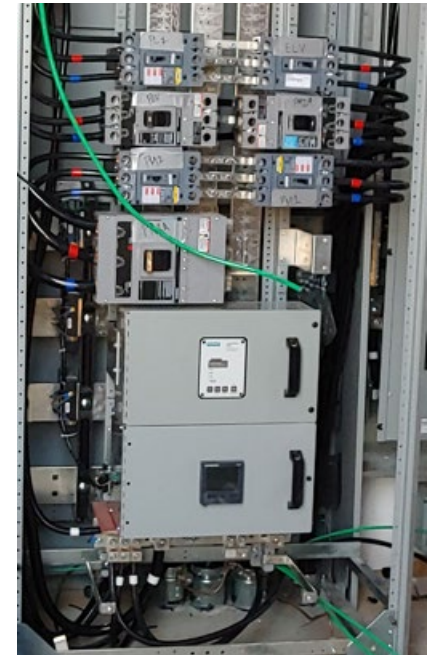

### Reminder:

Computer Rooms are conditioned floor areas with electronic equipment having a 20 W/sf of connected power density



# Controlled Environmental Horticulture (CEH)

## New Mandatory Requirements

### Indoor Growing:

- Dehumidification
- Lighting
- Electrical power distribution

### Conditioned Greenhouses:

- Envelope
- Space conditioning
- Lighting

### Key Highlights:

- Grow lights must have **high photosynthetic photon efficacy (PPE)**, is spectrum efficient, and have **dimming and timeclock controls**.
- Dehumidifiers must **meet federal dehumidifier standards** or **recover at least 75% of the heat** used for reheat.
- Conditioned greenhouses must have at least **two glazing layers**.



### Note:

This new section has a focus on cannabis growing. The space definition does not include building spaces where plants are grown for decoration.





# New Construction Prescriptive and Performance

Section 140.0

Minor changes to Envelope, Lighting, Service Hot Water

Major changes to Space Conditioning and Solar Electric

## Section 140.0

- Section 140.0 –General
- Section 140.1 –Performance Approach
- Section 140.2 –Prescriptive Approach
  
- Nonresidential occupancies in a mixed occupancy building shall comply with nonresidential requirements in Sections 120.0 through 141.1.

### Organization of Prescriptive Measures

- 140.3** Building Envelope
- 140.4** Space Conditioning Systems
- 140.5** Service Water Heating Systems
- 140.6** Indoor Lighting
- 140.7** Outdoor Lighting
- 140.8** Signs
- 140.9** Covered Processes
- 140.10** Photovoltaic and Battery Storage Systems

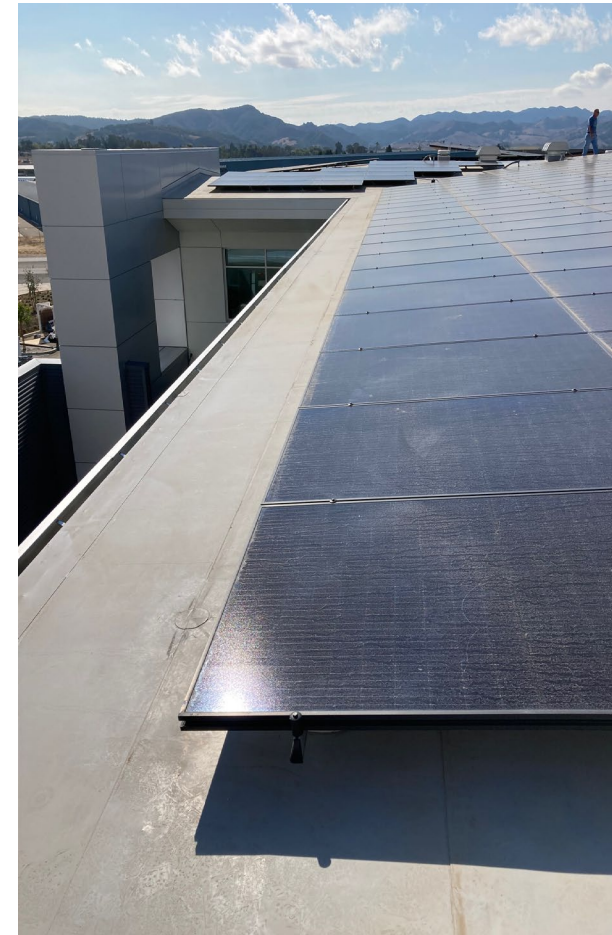



# Roofing Products –Solar Reflectance Index (SRI)

## Change for Non-Res Steep-sloped roofs

Steep-slope roofs in **CZ 1 and 3**:

- minimum aged solar reflectance of **0.20** and
- minimum thermal emittance of **0.75**, or
- minimum SRI of **16**

Steep-slope roofs **CZ 2 and 4-16**:

- minimum aged solar reflectance of **0.25** and
- minimum thermal emittance of **0.80**, or
- minimum SRI of **23**

### Main Take-aways:

CZ 2, 4-16 have new requirements for steep-slope roofs.  
 CZ 6,7,8 have new requirements for low-slope trade-off for aged solar reflectance.

Note: Separate sections for Guest Rooms of Hotel/Motel and Relocatable Public School Bldgs. (High-Rise Res has been removed.)

## Change for Non-Res Steep-sloped roofs

Low-slope roofs in **CZ 1-16**:

- minimum aged solar reflectance of 0.63 and
- minimum thermal emittance of 0.75, or
- minimum SRI of 75

TABLE 140.3 ROOF/CEILING INSULATION TRADEOFF FOR AGED SOLAR REFLECTANCE – NONRESIDENTIAL BUILDINGS

Aged Solar Reflectance	Metal Building Climate Zone 1-16 U-factor	Wood framed and Other Climate Zone 6-7-8 U-factor	Wood Framed and Other All Other Climate Zones U-factor
0.62-0.56	0.038	0.045	0.032
0.55-0.46	0.035	0.042	0.030
0.45-0.36	0.033	0.039	0.029
0.35-0.25	0.031	0.037	0.028



## Translation... Prescriptive U-0.060, U-0.071 and U-0.055 Nonresidential Metal Stud Wall Assemblies

Metal Stud	Cavity Insulation	Exterior Insulation	U-Factor	
2x4 @ 16" o.c.	R-13 -high density batt	R-2	0.151	← Min
	R-13 -high density batt	R-10	0.068	
	R-15 mineral/rock wool	R-12	0.060	← CZ 1, 6, 7
2x6 @ 16" o.c.	R-19 -low density batt	R-10	0.065	
	R-21 - high density batt or dense-packed cellulose	R-10	0.064	
2x4 @ 24" o.c.	R-13 -high density batt	R-14	0.053	
2x6 @ 24" o.c.	R-19 -low density batt	R-8	0.071	← CZ 3
	R-19 -low density batt	R-12	0.055	← CZ 2, 4, 5, 8-16
	R-21 - high density batt or dense-packed cellulose	R-14	0.049	

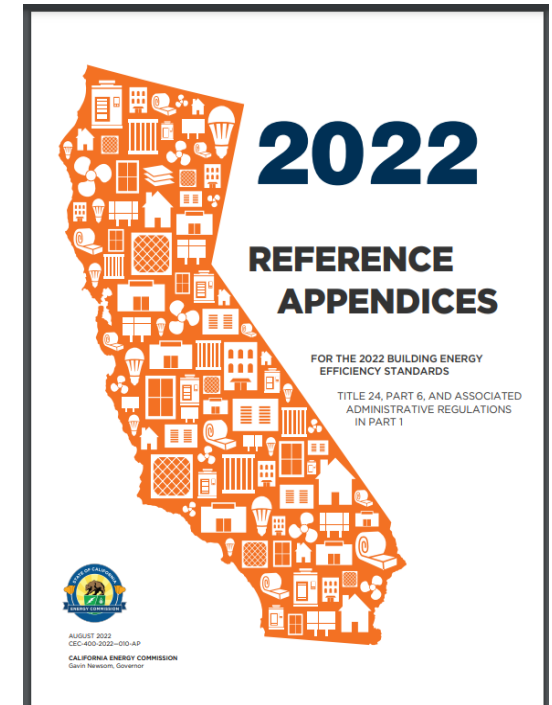

**Mandatory Minimum Metal-Framed Wall** is a weighted average U-factor of **U-0.151** (R-8 continuous insulation, or R-13 batt insulation between studs and 1/2" of continuous rigid insulation of R-2). It may be possible to meet the area-weighted average U-factor without continuous insulation if the appropriate siding materials are used.

# Vertical Fenestration –Con’t Table 140.3-B

Window performance is now climate zone specific for fixed windows, and curtainwalls or storefronts

Envelope	Fenestration	Vertical	Area-weighted Performance Rating	Climate Zone															
				1	2	3	4	5	6	7	8	9	10	11	12	13	14	15	16
				<b>Fixed Window</b>															
			<u>Max U-factor</u>	0.36	0.36	0.36	0.36	0.36	0.36	0.36	0.36	0.36	0.34	0.36	0.34	0.34	0.34	0.34	0.36
			<u>Max RSHGC</u>	0.25	0.25	0.25	0.25	0.25	0.25	0.25	0.25	0.25	0.22	0.25	0.22	0.22	0.22	0.22	0.25
			<u>Min VT</u>	0.42															
<b>Curtainwall or Storefront</b>																			
			<u>Max U-factor</u>	0.38	0.41	0.41	0.41	0.41	0.41	0.38	0.41	0.41	0.41	0.41	0.41	0.41	0.41	0.41	0.41
			<u>Max RSHGC</u>	0.25	0.26	0.26	0.26	0.26	0.26	0.25	0.26	0.26	0.26	0.26	0.26	0.26	0.26	0.26	0.26
			<u>Min VT</u>	0.46															
<b>Operable Window</b>																			
			<u>Max U-factor</u>	0.46															
			<u>Max RSHGC</u>	0.22															
			<u>Min VT</u>	0.32															
<b>Glazed Doors</b>																			
			<u>Max U-factor</u>	0.45															
			<u>Max RSHGC</u>	0.23															
			<u>Min VT</u>	0.17															
			<u>Max WWR%</u>	40%															

CZ 9,11-15  
new values

CZ 1 and 7  
new values





# Space Conditioning

**140.4(a)2** For Single zone systems with direct expansion (dx) cooling  $\leq 240,000$  Btu/hr:

- School building spaces:
  - CZ 2-15: Heat pump
  - CZ 1 and 16: Dual-fuel heat pump
- Retail and Grocery building spaces
  - CZ 2-15: Heat pump
  - CZ 1 and 16: cooling capacity  $<65,000$  Btu/hr: Furnace A/C; cooling capacity  $\leq 65,000$  Btu/hr: Dual-fuel heat pump
- Office, Financial Institutions and Library building spaces:
  - CZ 1-15: Heat pump
  - CZ 16: cooling capacity  $<65,000$  Btu/hr: Furnace A/C; cooling capacity  $\geq 65,000$  Btu/hr: Dual-fuel heat pump
- Office Spaces within the Warehouses
  - CZ 1-16: heat pump



Takeaway:  
Where demonstrated to be cost effective, the baseline is a heat pump.

**EXCEPTION to Section 140.4(a)2:** Systems utilizing recovered heat for space heating.



# Fan Power Budget –new calculation method for Systems $\geq 1$ kW

- Applies to **all fans** moving air in, out, and between conditioned spaces or circulating air to condition space
- Allowances vary by **system type, CFM, and floors served**
- At system design, flow cannot exceed budget
- See **Table 140.4-A Supply Fan Power Allowances** (Watts/cfm)-extensive—Includes 100% OA, Energy Recovery, low turndown single zone VAV, etc
- For elevations >3,000 feet, multiply fan budget by **Correction Factor listed in Table 140.4-C**

Excerpt from Table 140.4-A

<u>Airflow</u>	<u>Multi-Zone VAV Systems <math>\leq 5,000</math> cfm<sup>1</sup></u>	<u>Multi-Zone VAV Systems &gt;5,000 and <math>\leq 10,000</math> cfm<sup>1</sup></u>	<u>Multi-Zone VAV Systems &gt;10,000 cfm<sup>1</sup></u>	<u>All Other Fan Systems <math>\leq 5,000</math> cfm</u>	<u>All Other Fan Systems &gt;5,000 and <math>\leq 10,000</math> cfm</u>	<u>All Other Fan Systems &gt;10,000 cfm<sup>1</sup></u>
<u>Supply System Base Allowance for AHU serving spaces <math>\leq 6</math> floors away).</u>	<u>0.395</u>	<u>0.453</u>	<u>0.413</u>	<u>0.232</u>	<u>0.256</u>	<u>0.236</u>
<u>Supply system base allowance for AHU serving spaces &gt; 6 floors away</u>	<u>0.508</u>	<u>0.548</u>	<u>0.501</u>	<u>0.349</u>	<u>0.356</u>	<u>0.325</u>
<u>MERV 13 to MERV 16 Filter upstream of thermal conditioning equipment (<del>mid-</del><u>if two times the clean filter pressure drop</u>)<sup>2</sup></u>	<u>0.136</u>	<u>0.114</u>	<u>0.105</u>	<u>0.139</u>	<u>0.120</u>	<u>0.107</u>

Takeaway:  
 New method of calculating fan power budget is more nuanced.  
 Applies to fans 1kW or larger –previously 5 hp (3.7 kW)

## Economizers –Update to Cooling Air Handler Threshold

- Prescriptively required when the air handler has a **cooling capacity > 33,000 Btu/hr** (previously 54,000 Btu/hr)
  - Design criteria
  - Smaller rooftop units
  - Smaller split DX air handlers
  - VRFs and mini-splits
- Economizer **trade-off** for cooling system efficiency allowed –**Table 140.4-F**
- **New Exception** for air handlers that have a design **cooling capacity < 54,000 Btu/hr** and ventilation provided by a **DOAS with exhaust air heat recovery** –Refer to Sections 140.4(p),(q) and 120.1(c)3
- Guest Rms of Hotel/Motel and Computer Rms excluded from 140.4(e)
- **New Exception** for **controlled environment horticulture** spaces where carbon dioxide enrichment is required

Takeaway:  
Broadening application  
of requirements for  
economizers to lower  
capacity units



# New –High Capacity Space Heating Gas Boiler Systems

For CZ 1-6, 9-14, and 16:

New requirements for space heating gas boiler systems with total input **1 million -10 million Btu/hr** (boilers <300,000 Btu/hr not included in the total system input)

- Boiler efficiency: **90% minimum thermal efficiency**
- Hot water distribution **design criteria** –Coils and other heat exchangers:
  - Entering/return water temp 120 deg F or less, or
  - flow rate is reduced to 20% or less of the design flow of the operating boilers

**EXCEPTION to 140.4(k)8** Where **25%** of annual space heating requirement is provided by **renewable, site recovered energy or heat recovery chillers**.



**Design implications:** To achieve the 90% efficiency, some or all of the boilers used must have condensing capability. Boilers within the same building but on separate loops are not considered to be part of the same system.





# Dedicated Outdoor Air System (DOAS)

## –Section has been re-written

Units that are used to filter, condition or temper 100% outside air and are separate from space conditioning systems serving the same space:

- Supply & exhaust fans:
  - ERV, HRV, DX-DOAS
  - Minimum of 3 speeds to facilitate system balancing
- DOAS with mechanical cooling providing ventilation to multiple zones and operating in conjunction with zone heating and cooling systems shall **not use heating or heat recovery** to warm supply air above 60°F when representative building loads or outdoor air temperature indicate that **majority of zones require cooling**



Meant to limit reheating,  
and conserve energy



## Example of One Type of Energy / Heat Recovery Ventilation (ERV / HRV)

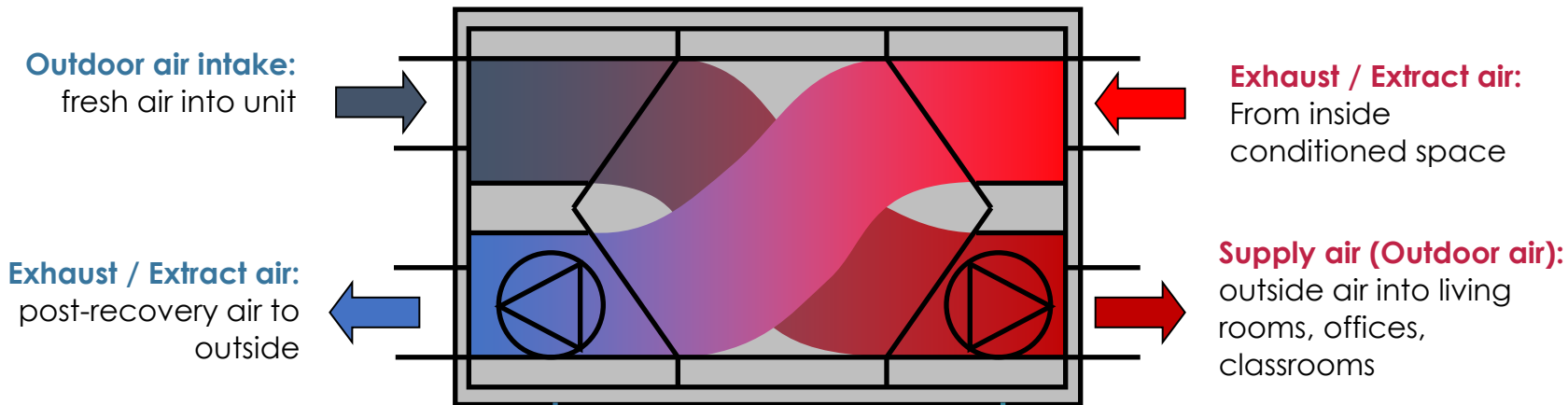

- Thin membrane, multi-channel pathway for the Outdoor/Supply air going in and the Exhaust/Extracted air going out
- The air pathways do not mix



## Dedicated Outdoor Air System (DOAS) –con't

- DOAS unit fan systems:
  - If input power < 1 kW, shall not exceed a total combined fan power of 1.0 W/cfm
  - In input power  $\geq$  1 kW, shall meet requirements of 140.4(c)
- Supply air:
  - Shall be delivered directly to the occupied space or at the outlet of any terminal heating or cooling coils
  - Shall cycle off any zone heating and cooling equipment fans, circulation pumps and terminal unit fans when there is no call for heating or cooling in the zone.
  - Exceptions apply- 140.4(p)2

Meant to eliminate  
energy waste



# New –Exhaust Air Heat Recovery

Fan systems designed to operate to the criteria listed in either Table 140.4-J or K **shall include an exhaust air heat recovery system**. Tables are based on Climate Zone and the percent of outdoor air at full design airflow.

**Table 140.4-J** (< 8,000 hrs/yr)

**Table 140.4-K** (≥ 8,000 hrs/yr)

Values are the design supply fan airflow rate in CFM

**Table 140.0-K** ENERGY RECOVERY REQUIREMENTS BY CLIMATE ZONE AND PERCENT OUTDOOR AIR AT FULL DESIGN AIRFLOW (≥8,000 HOURS / YEAR)

<u>% Outdoor Air at Full Design Airflow</u>	<u>1</u>	<u>2</u>	<u>3</u>	<u>4</u>	<u>5</u>	<u>6</u>	<u>7</u>	<u>8</u>	<u>9</u>	<u>10</u>	<u>11</u>	<u>12</u>	<u>13</u>	<u>14</u>	<u>15</u>	<u>16</u>
≥10% and <20%	≥10,000	≥10,000	NR	NR	NR	NR	NR	NR	NR	≥40,000	≥40,000	≥20,000	≥10,000	≥10,000	≥10,000	≥10,000
≥20% and <30%	≥2,000	≥5,000	≥13,000	≥9,000	≥9,000	NR	NR	NR	NR	≥15,000	≥15,000	≥5,000	≥5,000	≥5,000	≥5,000	≥5,000
≥30% and <40%	≥2,000	≥3,000	≥10,000	≥6,500	≥6,500	NR	NR	NR	≥15,000	≥7,500	≥7,500	≥3,000	≥3,000	≥3,000	≥3,000	≥3,000
≥40% and <50%	≥2,000	≥2,000	≥8,000	≥6,000	≥6,000	NR	NR	NR	≥12,000	≥6,000	≥6,000	≥2,000	≥2,000	≥2,000	≥2,000	≥2,000
≥50% and <60%	≥2,000	≥2,000	≥7,000	≥6,000	≥6,000	NR	NR	≥20,000	≥10,000	≥5,000	≥5,000	≥2,000	≥2,000	≥2,000	≥2,000	≥2,000
≥60% and <70%	≥2,000	≥2,000	≥6,000	≥6,000	≥6,000	NR	NR	≥18,000	≥9,000	≥4,000	≥4,000	≥2,000	≥2,000	≥2,000	≥2,000	≥2,000
≥70% and <80%	≥2,000	≥2,000	≥6,000	≥5,000	≥5,000	NR	NR	≥15,000	≥8,000	≥3,000	≥3,000	≥2,000	≥2,000	≥2,000	≥2,000	≥2,000
≥80%	≥2,000	≥2,000	≥6,000	≥5,000	≥5,000	NR	NR	≥12,000	≥7,000	≥3,000	≥3,000	≥2,000	≥2,000	≥2,000	≥2,000	≥2,000



## New Section—Exhaust Air Heat Recovery

- Fan System must meet either
  - Sensible energy recovery ration of at least 60% OR
  - Enthalpy recovery ratio of at east 50% for both heating and cooling design conditions, and be rated in accordance to AHRI 1060
- AND Energy recover bypass or control to:
  - Disable energy recovery AND directly economize with ventilation air based on outdoor air temperature limits specified in Table 140.4-G
  - For energy recovery systems where the transfer of energy cannot be stopped, bypass shall prevent total airflow rate of either outdoor air or exhaust air through the energy recovery exchanger from exceeding 10% of the full design airflow rate

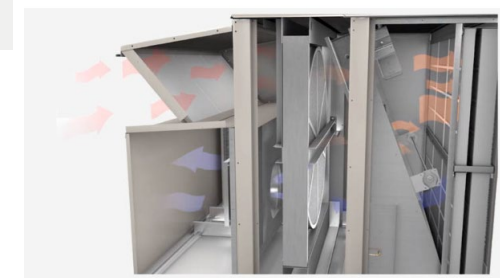

Many Exceptions included, see Section 140.4(q)

# Domestic Hot Water –Prescriptive (140.5) or Performance (140.1)

## Hotel/Motel

- Same requirements as multifamily section 170.2(d) for individual or central system

## Other Occupancies

- Any water heater that meets the Mandatory requirements
- Must be at least **90% efficiency** if the combined input rate is  $\geq 1,000,000$  Btu/hr, with some exceptions
- **Exception:** A water heating system serving an **individual bathroom** space may be an **instantaneous electric** water heater

## School Buildings <25,000 ft<sup>2</sup> and <4 stories

- CZ 2-15: a **HPWH** system



Residential – Single and Multifamily



Commercial – Hospitality, Retail, Schools



# Indoor Lighting

Category	Table	Change
Power Adjustment Factors (PAF)	<b>Table 140.6-A</b>	Savings reductions in <u>office</u> applications
Complete Building Lighting Allowances	<b>Table 140.6-B</b>	Reductions in some lighting power density values; <u>Museum Building</u> type added
Area Category Lighting Allowances	<b>Table 140.6-C</b>	Lighting power density and additional allowance changes –both reductions and increases
Tailored Lighting Allowances	<b>Table 140.6-D</b>	Lighting power density values have been reduced
Tailored Lighting General Allowances	<b>Table 140.6-G</b>	All lighting power density values have been reduced



# Outdoor Lighting

Category	Table	Change
Lighting Zone Designations	<b>Table 10-114-A</b>	Examples for each category given; Urban now has 2 zones- urban clusters and urbanized areas
General Hardscape Allowances	<b>Table 140.7-A</b>	All values reduced; Asphalt and concrete are no longer differentiated; more details in footnotes
Specific Lighting Applications	<b>Table 1407-B</b>	Security cameras added as new application for urban designations for illuminated general hardscape

The Census Bureau identifies two types of urban areas (2010 Census):

- Urbanized Areas (UAs) of 50,000 or more people;
- Urban Clusters (UCs) of at least 2,500 and less than 50,000 people.
- Rural encompasses all population, housing, and territory not included within an urban area.

The specific criteria used to define urban areas for the 2010 Census were published in the Federal Register of August 24, 2011.

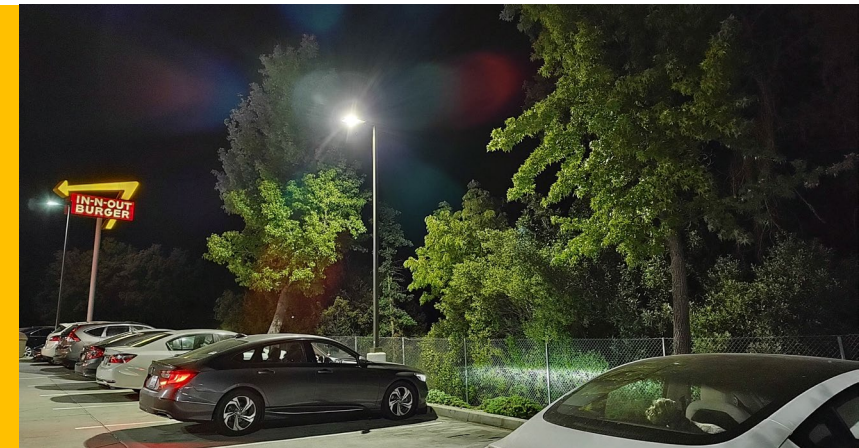



# Covered Processes

**(a) Computer Rooms** with a power density  $> 20$  W/sf:

- New language added allowing for refrigerant economizers with Net Sensible COP by climate zone
- Other language changes affecting unit selections
- New language for Uninterruptible Power Supplies (UPS) efficiencies

Table 140.9-A: Minimum Pumped Refrigerant Economizer CRAC Net Sensible COP by Climate Zone

<u>Climate Zone</u>	<u>Net Sensible COP</u>
<u>Climate Zone 1</u>	<u>5.5</u>
<u>Climate Zone 2</u>	<u>4.5</u>
<u>Climate Zone 3</u>	<u>4.2</u>
<u>Climate Zone 4</u>	<u>3.8</u>
<u>Climate Zone 5</u>	<u>4.3</u>
<u>Climate Zone 6</u>	<u>2.7</u>
<u>Climate Zone 7</u>	<u>2.3</u>
<u>Climate Zone 8</u>	<u>2.8</u>
<u>Climate Zone 9</u>	<u>3.3</u>
<u>Climate Zone 10</u>	<u>3.4</u>
<u>Climate Zone 11</u>	<u>3.9</u>
<u>Climate Zone 12</u>	<u>4.0</u>
<u>Climate Zone 13</u>	<u>3.7</u>
<u>Climate Zone 14</u>	<u>3.7</u>
<u>Climate Zone 15</u>	<u>3.6</u>
<u>Climate Zone 16</u>	<u>3.0</u>

# UPS in Computer Rooms

Uninterruptible Power Supply (UPS) efficiency requirement when serving a computer room:

- Alternating current-output UPS systems shall meet or exceed minimum average efficiencies in Table 140.9-B

**Table 140.9-BA Alternating Current-Output Uninterruptible Power Supply Minimum Average Efficiency**

	<u>Voltage and Frequency Dependent</u>	<u>Voltage Independent</u>	<u>Voltage and Frequency Independent</u>
<u>P &lt; 350 W</u>	$5.71 \times 10^{-5} \times P + 0.962$	$5.71 \times 10^{-5} \times P + 0.964$	$0.011 \times \ln(P) + 0.824$
<u>350 W &lt; P &lt; 1,500 W</u>	<u>0.982</u>	<u>0.984</u>	<u><math>0.011 \times \ln(P) + 0.824</math></u>
<u>1,500 W &lt; P &lt; 10,000 W</u>	$0.981 - E_{MOD}$	$0.980 - E_{MOD}$	$0.0145 \times \ln(P) + 0.800 - E_{MOD}$
<u>P &gt; 10,000 W</u>	<u>0.970</u>	<u>0.940</u>	<u><math>0.0058 \times \ln(P) + 0.886</math></u>

New Table!



# Photovoltaic (PV) –Applicable Bldg Type and System Size

Use the smaller of:

1.  $kW_{PV} = (CFA \times A)/1000$

- CFA = conditioned floor area in square feet
- A = PV capacity factor from Table 140.10-A

OR

2. Total SARA x 14 W/ft<sup>2</sup>

Table 140.10-A – PV Capacity Factors

Climate Zone	Factor A – Minimum PV Capacity (W/ft <sup>2</sup> of conditioned floor area)		
	1, 3, 5, 16	2, 4, 6-14	15
Grocery	2.62	2.91	3.53
High-Rise Multifamily	1.82	2.21	2.77
Office, Financial Institutions, Unleased Tenant Space	2.59	3.13	3.80
Retail	2.62	2.91	3.53
School	1.27	1.63	2.46
Warehouse	0.39	0.44	0.58
Auditorium, Convention Center, Hotel/Motel, Library, Medical Office Building/Clinic, Restaurant, Theater	0.39	0.44	0.58

Applies to new construction as listed in Table 140.10-A or mixed occupancy where one or more of these building types constitute at least 80% of the floor area of the building



# Solar Access Roof Area (SARA)



- Area of a buildings' roof space capable of supporting PV system
- Area of all roof space on covered parking areas, carports and other newly constructed structures onsite that are compatible with supporting a PV system per CBC 1511.2

## Exceptions:

- Any roof area that has <70% annual solar access
- Occupied roof areas per CBC 503.1.4
- Roof area not otherwise available due to compliance with other building code requirements if confirmed by the Executive Director

## PV System Size (kW<sub>dc</sub>):

$$kW_{PV} = \frac{CFA \times A}{1000}$$

### EQUATION 140.10-A

**CFA:** Conditioned Floor Area

**A:** Climate Zone Factor

No PV required if:

- PV size < 4 kWdc;
- SARA < 80 sq ft contiguous or < 3% of the CFA
- Snow loading parameters

**OR**

**the PV size = 14 W/sq ft x SARA**

SARA is the Solar Accessible Roof Area (area receiving 70% solar insolation)



VTA Housing Ohlone Station, San Jose, CA (CZ 4)

Restaurant -- 2,000 sf

SARA = 4,500 sf

Retail – 3,500 sf

Office and Unleased – 7,000 sf

$$kW_{PV} = (2000 \times 0.44) + (3500 \times 2.91) + (7000 \times 3.13) / 1000$$

$$kW_{PV} = 33 \text{ kW}$$

**OR**

$$kW_{PV} = 14 \text{ W/sf} \times 4,500 \text{ sf} / 1000$$

$$kW_{PV} = 63 \text{ kW}$$



# Example Estimating Quantity of Panels

## Given a PV System Size (kWdc)

- Take the PV System Size (kWdc) calculated from EQ 170.2-C/D and multiply by 1000 to convert to watts.
- Look at different PV panel products and look for nominal power output (W, watts) and the panel dimensions.
- Divide PV System Size (watts) by a panel's nominal power (W, watts) to determine an estimated number of panels.

### Sunpower x-series-commercial x21-470-com

Electrical Data	
	SPR-X21-470-COM SPR-
Nominal Power (P <sub>nom</sub> ) <sup>5</sup>	470 W
Power Tolerance	+5/-0%
Avg. Panel Efficiency <sup>6</sup>	21.7%
Rated Voltage (V <sub>mpp</sub> )	77.6 V
Rated Current (I <sub>mpp</sub> )	6.06 A
Open-Circuit Voltage (V <sub>oc</sub> )	91.5 V
Short-Circuit Current (I <sub>sc</sub> )	6.45 A

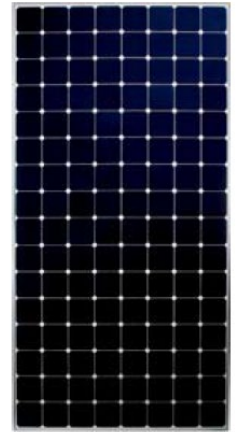

SPR-X21-470-COM

For estimating a layout, use the outer panel dimensions and add 0.5" as an average value for spacing between panels to allow for some of the more common mounting hardware.

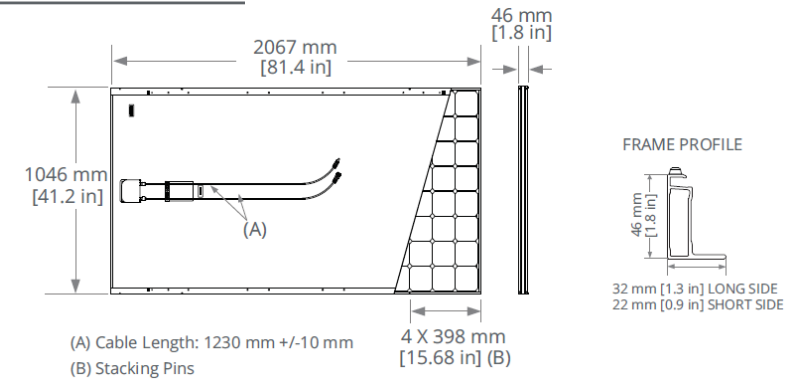

$$\text{PV System Size} = 33 \text{ kW} \times 1000 = 33000 \text{ W}$$

$$\begin{aligned} \text{No of Panels} &= \text{PV System Size} / \text{Panel wattage} \\ &= 33000 \text{ W} / 470 \text{ W} \\ &= 70.2, \quad \text{call it } \mathbf{71 \text{ Panels}} \end{aligned}$$



# Battery Storage

All buildings **required** to have a **PV system** shall also have a **battery storage system**.

**Reminder:** Battery system must meet **both** rated **energy** capacity (kWh) and the rated **power** capacity (kW)  
 Calculate the energy and power capacities for each occupancy type in mixed use buildings, and sum the values.

### Rated Energy capacity :

$$\text{kWh} = \text{kW}_{\text{PVdc}} \times B / D^{0.5}$$

**D** is the rated single charge-discharge cycle AC to AC efficiency of the battery

### Rated Power capacity:

$$\text{kW} = \text{kW}_{\text{PVdc}} \times C$$

*Table 140.10-B – Battery Storage Capacity Factors*

	<u>Factor B – Energy Capacity</u>	<u>Factor C – Power Capacity</u>
<u>Storage-to-PV Ratio</u>	<u>Wh/W</u>	<u>W/W</u>
<u>Grocery</u>	<u>1.03</u>	<u>0.26</u>
<u>High-Rise Multifamily</u>	<u>1.03</u>	<u>0.26</u>
<u>Office, Financial Institutions, Unleased Tenant Space</u>	<u>1.68</u>	<u>0.42</u>
<u>Retail</u>	<u>1.03</u>	<u>0.26</u>
<u>School</u>	<u>1.87</u>	<u>0.46</u>
<u>Warehouse</u>	<u>0.93</u>	<u>0.23</u>
<u>Auditorium, Convention Center, Hotel/Motel, Library, Medical Office Building/Clinic, Restaurant, Theater</u>	<u>0.93</u>	<u>0.23</u>

# Battery Storage

## Exceptions:

- If installed PV system size  $< 15\%$  of the size determined by Equation 140.10-A
- In buildings with system requirements with  $< 10$  kWh rated capacity
- For multi-tenant buildings, the energy and power capacities of the battery storage system shall be based on the tenant spaces with more than 5,000 ft<sup>2</sup> of conditioned floor area
- In climate zone 1, no battery storage system is required for offices, schools, and warehouses.





# Additions and Alterations

Section 141.0

Minor Changes: Highlight Alterations for HVAC, Hot Water and Roofing

# Alterations

## Wall Alterations

- When **25% or more of the building envelope wall area** is altered it needs to meet the air barrier design and material requirements for newly constructed building
- **See 3.2.4 for air barrier details and blower door testing**
- If the **air leakage rate exceeds 0.4 cfm/sq ft** a Visual Inspection and Diagnostic Evaluation must be completed in accordance with Nonresidential Appendix NA5.7 to find the sources of excessive leakage. The leaks shall then be sealed.

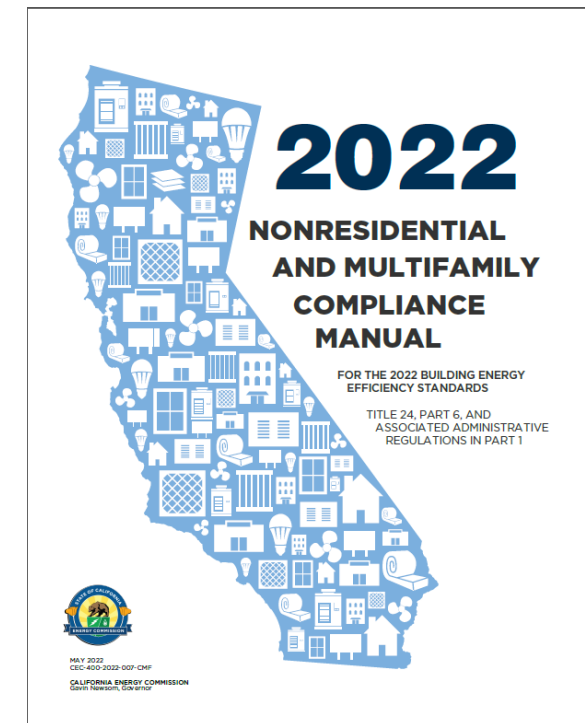

## Tip:

The 2022 Nonresidential and Multifamily Compliance Manual has numerous **alteration scenarios with potential cost effective solutions and considerations, especially for roofing and HVAC roof top units**— See Section 3.6 starting at pg 3-84.



# Alterations

## Roofing Alterations

- When 50% or 2000 sf of existing roof is replaced or recovered, the new requirements under **Section 140.3(a)1A** are triggered
- **Table 141.0-B** Roof/Ceiling Insulation Trade-offs for Low-Sloped Aged Solar Reflectance has updated U-factors and a new climate zone organization
- For **low-sloped roofs**, the area of the roof recover or roof replacement shall be insulated to the level specified in **Table 141.0-C**.

End result of changes is higher levels of roof insulation

*TABLE 141.0-C INSULATION REQUIREMENTS FOR ROOF ALTERATIONS*

<u>Climate Zone</u>	<u>Continuous Insulation R-value</u>	<u>U-factor</u>
<u>1-5, 9-16</u>	<u>R-23</u>	<u>0.037, with at least R-10 above deck</u>
<u>6-8</u>	<u>R-17</u>	<u>0.047, with at least R-10 above deck</u>



## Additions and Alterations

- **HVAC alterations –New or replacement space conditioning system or components:**
  - **Additional fan power allowances** are available in **Table 141.0-D** and can be added to the allowances in Tables 140.4-A and 140.4-B (exceptions apply)
- **Duct alterations** (considered ‘new’ ducts if replacing 75% of the duct system)
  - The duct system that is connected to the new or replaced space-conditioning system equipment shall be sealed and HERS tested < **6%** leakage
  - Duct extensions for constant volume, single zone systems serving less than 5,000 sf, shall be sealed and HERS tested < **15%**
- **Water Heater alterations**
  - Service water heating systems shall meet the requirements of 140.5(a)2 and 140.5(b), except for the solar water heating requirements
  - Follows the new requirements for Hotel/Motel, Non-Res, and large capacity boiler efficiency

Excerpt from Table 141.0-D

<u>Airflow</u>	<u>Multi-Zone VAV Systems<sup>1</sup> ≤5,000 cfm</u>	<u>Multi-Zone VAV Systems<sup>1</sup> &gt;5,000 and ≤10,000 cfm</u>	<u>Multi-Zone VAV Systems<sup>1</sup> &gt;10,000 cfm</u>	<u>All Other Fan Systems ≤5,000 cfm</u>	<u>All Other Fan Systems &gt;5,000 and ≤10,000 cfm</u>	<u>All Other Fan Systems &gt;10,000 cfm</u>
<u>Supply Fan System Additional Allowance</u>	<u>0.135</u>	<u>0.114</u>	<u>0.105</u>	<u>0.139</u>	<u>0.12</u>	<u>0.107</u>
<u>Supply Fan System Additional Allowance In Unit with Adapter Curb</u>	<u>0.033</u>	<u>0.033</u>	<u>0.043</u>	<u>0.000</u>	<u>0.000</u>	<u>0.000</u>
<u>Exhaust/Relief/Return/Transfer Fan System Additional Allowance</u>	<u>0.07</u>	<u>0.061</u>	<u>0.054</u>	<u>0.07</u>	<u>0.062</u>	<u>0.055</u>

**Reminder:** Additions and Alterations can be shown to comply with the Energy Code via Performance (computer modeling) or Prescriptively (checklist).



# Energy Code Coach

[www.3c-ren.org](http://www.3c-ren.org)

## 3C-REN offers a Code Coach Service



**ENERGY CODE COACH**

Call anytime, response within one business day  
**805-220-9991**

Or submit online:  
[www.3c-ren.org/ecc](http://www.3c-ren.org/ecc)

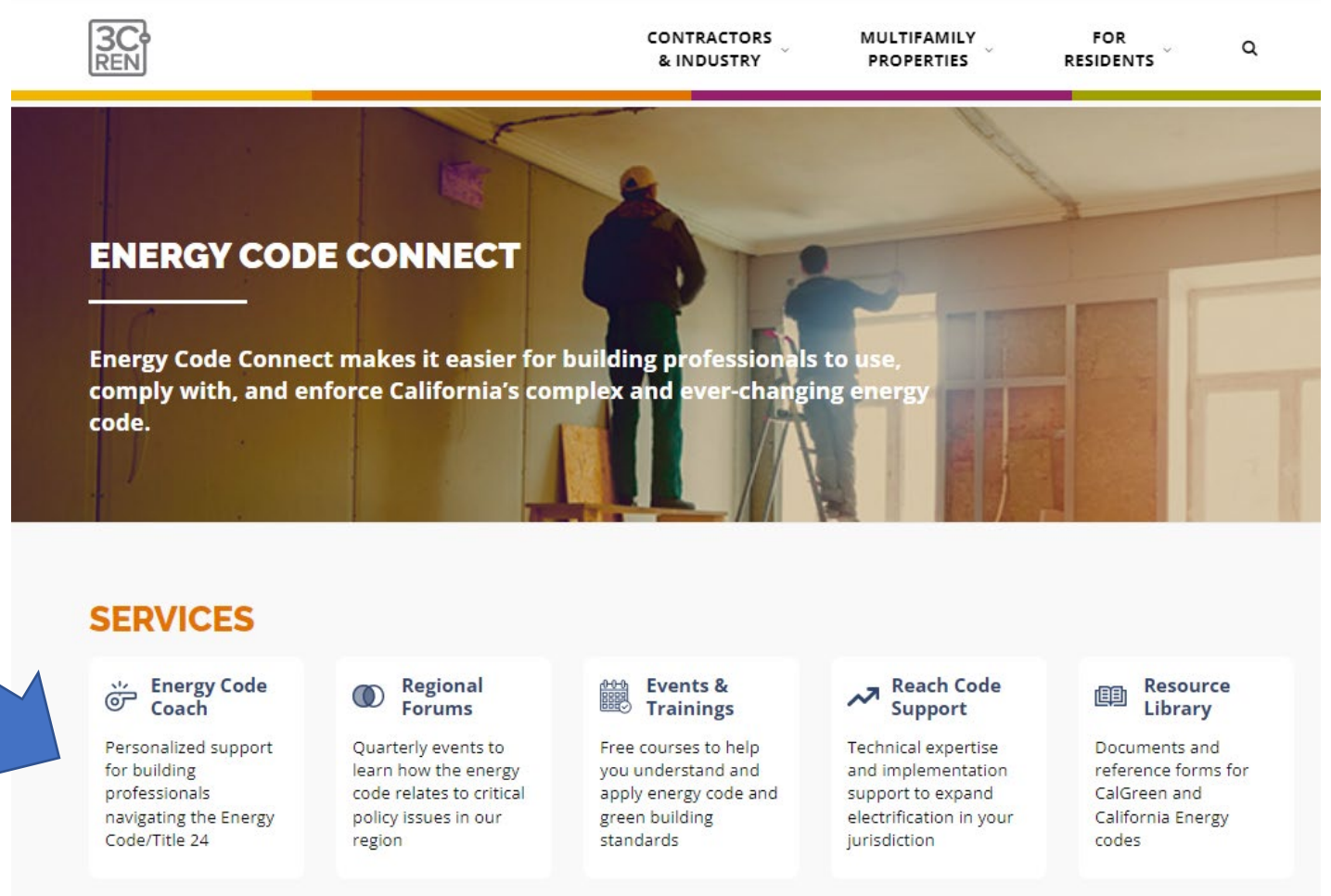

**3C REN**

CONTRACTORS & INDUSTRY | MULTIFAMILY PROPERTIES | FOR RESIDENTS

### ENERGY CODE CONNECT

Energy Code Connect makes it easier for building professionals to use, comply with, and enforce California's complex and ever-changing energy code.

#### SERVICES

- Energy Code Coach**  
Personalized support for building professionals navigating the Energy Code/Title 24
- Regional Forums**  
Quarterly events to learn how the energy code relates to critical policy issues in our region
- Events & Trainings**  
Free courses to help you understand and apply energy code and green building standards
- Reach Code Support**  
Technical expertise and implementation support to expand electrification in your jurisdiction
- Resource Library**  
Documents and reference forms for CalGreen and California Energy codes



# Closing

- Continuing Education Units Available
  - Contact [shuskey@co.slo.ca.us](mailto:shuskey@co.slo.ca.us) for AIA and ICC LUs
- Coming to Your Inbox Soon!
  - Slides, Recording, & Survey – Please Take It and Help Us Out!
- Upcoming Courses:
  - May 23<sup>rd</sup> – [Targeting Zero Net Carbon Design: Class 1](#)
  - May 31<sup>st</sup> – [2022 Energy Code Single Family \(ICC Chapter Series\)](#)
  - June 6<sup>th</sup> – [Good Electrification for Solar Contractors](#)
  - June 8<sup>th</sup> – [Acceptance Testing and Commissioning for Nonresidential](#)
  - June 14<sup>th</sup> – [2022 Energy Code Multi-Family \(ICC Chapter Series\)](#)
  - June 20<sup>th</sup> – [Energy Performance for ZNC Operations: Class 2](#)
  - June 22<sup>nd</sup> – [All-electric Options for Tiny Homes and ADUs: SLO Guild Hall](#)
  - June 26<sup>th</sup> – 30<sup>th</sup> - [Passive House Designer/Consultant Certification](#) – Submit an interest form!

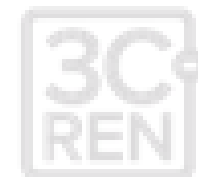



**Thank you!**

For more info:  
[3c-ren.org](https://3c-ren.org)

For questions:  
[info@3c-ren.org](mailto:info@3c-ren.org)



TRI-COUNTY REGIONAL ENERGY NETWORK  
SAN LUIS OBISPO • SANTA BARBARA • VENTURA