



We will be starting soon!

Thanks for joining us



Energy Code Implementation: Single Family Additions and Alterations



Jennifer Rennick, AIA, CEA – In Balance Green Consulting
Grant Murphy, CEA – In Balance Green Consulting

March 13, 2024



Zoom Orientation

- Please be sure your full name is displayed
- Please **mute** upon joining
- Use "Chat" box to share questions or comments
- Under "Participant" select "Raise Hand" to share a question or comment verbally
- The session may be **recorded** and posted to 3C-REN's on-demand page. Feel free to ask questions via the chat and keep video off if you want to remain anonymous in the recording.

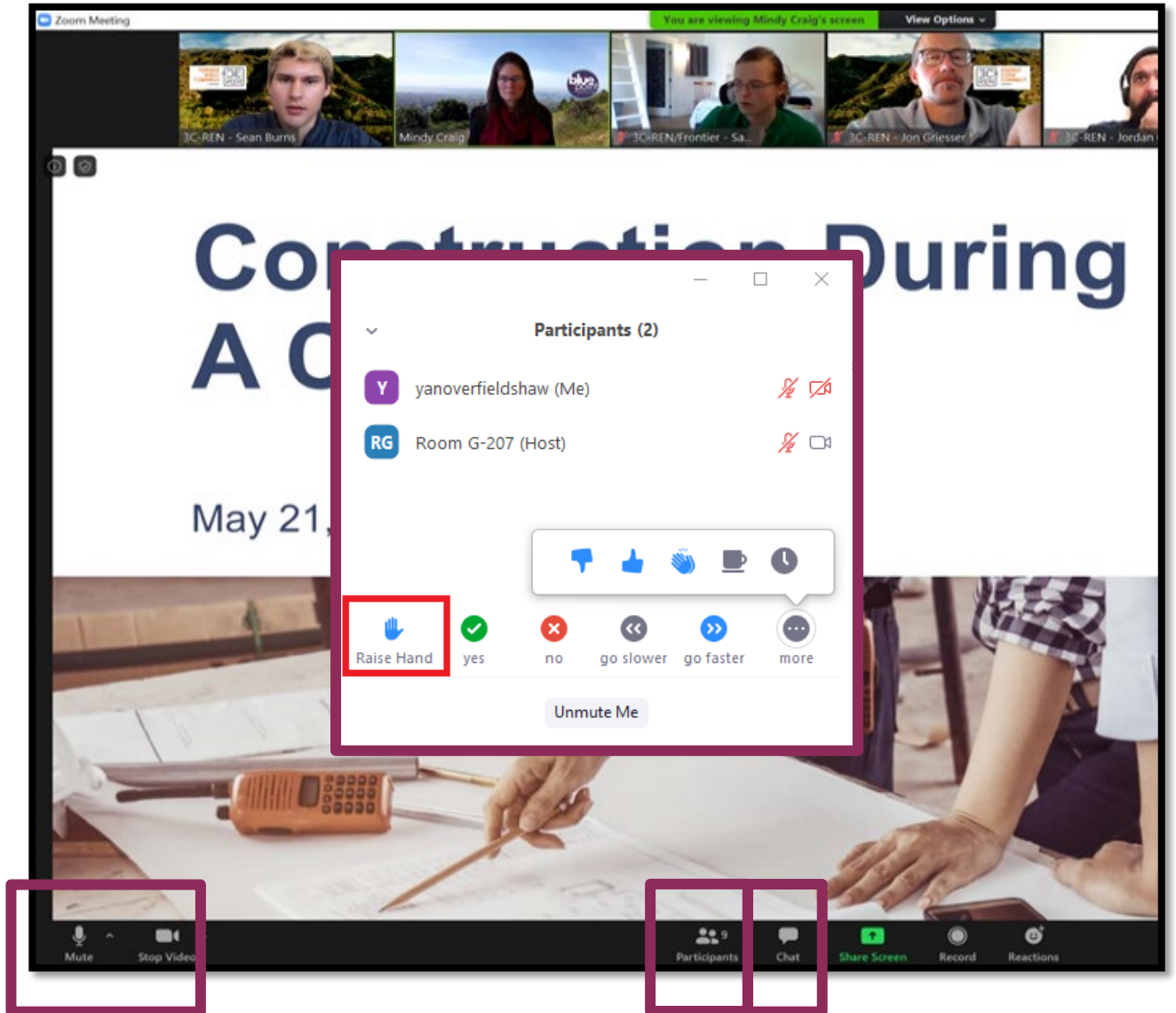

3C-REN: Tri-County Regional Energy Network

- Three counties working together to improve energy efficiency in the region
- Services for –
 - **Building Professionals:** industry events, training, and energy code compliance support
 - **Households:** free and discounted home upgrades
- Funded by ratepayer dollars that 3C-REN returns to the region

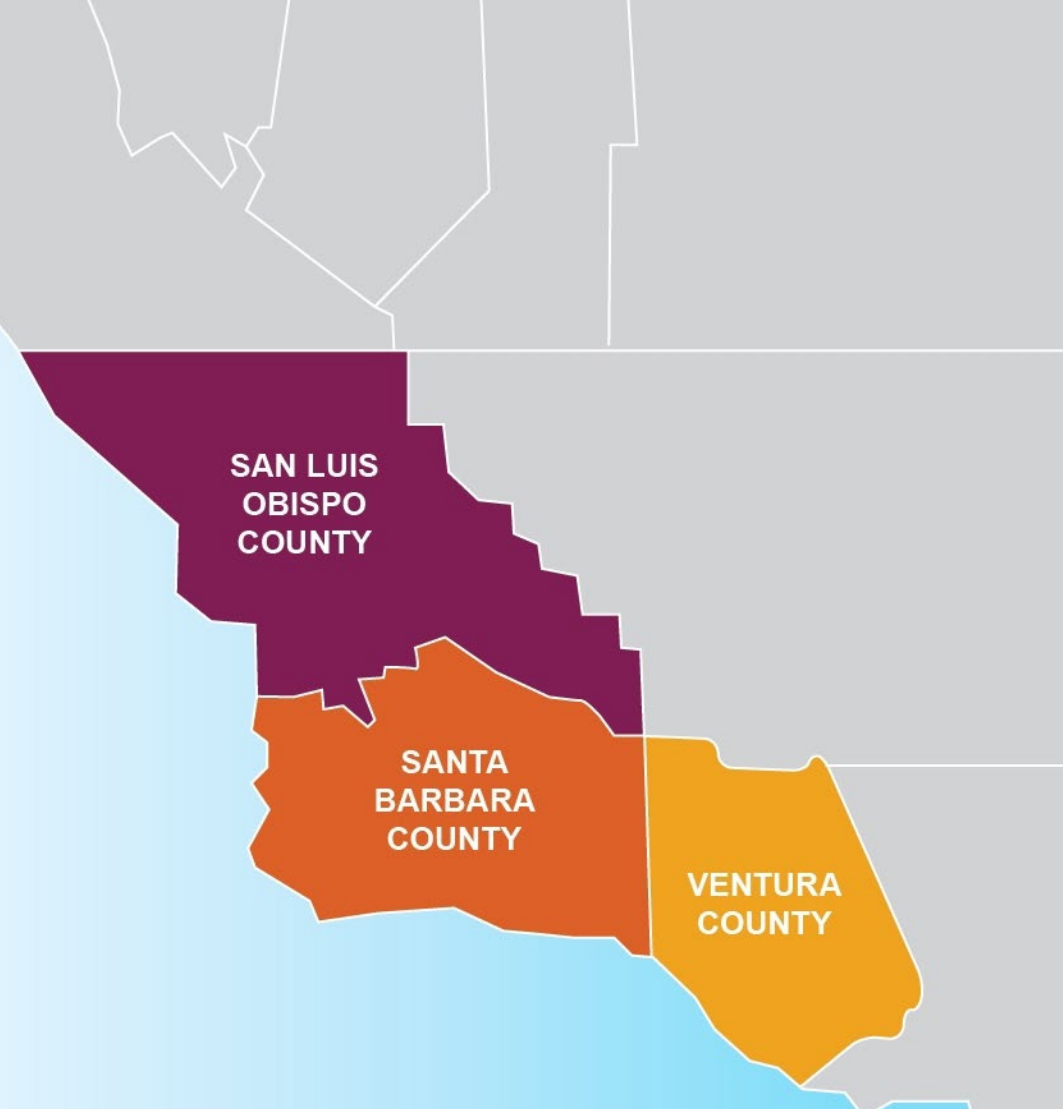



**ENERGY
CODE
CONNECT**

- Serves all building professionals
- Three services –
 - **Energy Code Coach**
 - **Training and Support**
 - **Regional Forums**
- Makes the Energy Code easy to follow

Energy Code Coach:
3c-ren.org/codes
805.781.1201

Event Registration:
3c-ren.org/events





BUILDING PERFORMANCE TRAINING

- Serves current and prospective building professionals
- Expert instruction:
 - **Technical skills**
 - **Soft skills**
- Helps workers to thrive in an evolving industry

Event Registration:
3c-ren.org/events





HOME
ENERGY
SAVINGS

Multifamily (5+ units)

- No cost technical assistance
- Rebates up to \$750/apartment plus additional rebates for specialty measures like heat pumps

Single Family (up to 4 units)

- Sign up to participate!
- Get paid for the metered energy savings of your customers

Enrollment:
3C-REN.org/contractor-participation



Energy Code Implementation Series

Since the energy code update took effect in January 2023, the industry is adjusting to design, detailing and construction to meet compliance. In this series, we'll review the code requirements with a focus on what to include in construction documents to streamline the permitting process and tips for construction to ease sign-offs and occupancy.

- Energy Code Implementation: Single Family New Construction
- **Energy Code Implementation: Single Family Additions and Alterations**
- Energy Code Implementation: ADUs
- Energy Code Implementation: Multi-Family
- Energy Code Implementation: Non-Residential

<https://www.3c-ren.org/calendar-of-events-and-trainings/>



Today's Learning Objectives

- Understand the current metrics used in the energy code for evaluating compliance, and how choices for electric or gas equipment may impact that compliance.
- Review key mandatory measures, the prescriptive “recipe card” approach, and the options for using the building performance approach.
- Recognize where barriers or stumbling blocks may occur within permitting and construction and tips for documentation to smooth out the process.
- How to access resources for energy code compliance

1.5 AIA HSW LU approved for this course

0.15 ICC CEU approved for this course



Agenda

1. 2022 Energy Code –Broad Overview
2. Additions and Alterations for Single Family
3. Envelope –Walls, Windows and Attics
4. Domestic Water Heating
5. Electrification or Electric Ready
6. HERS Verification –Opportunity for Credit





2022 Energy Code

Big Picture Items

Key Terms

Performance Method

California Energy Commission (CEC)

Our Responsibilities

- Advancing State Energy Policy
- Achieving Energy Efficiency
- Investing in Energy Innovation
- Developing Renewable Energy
- Transforming Transportation
- Overseeing Energy Infrastructure
- Preparing for Energy Emergencies

EXPLORE OUR CORE RESPONSIBILITIES >



ABOUT

The California Energy Commission is leading the state to a 100 percent clean energy future. As the state's primary energy policy and planning agency, the Energy Commission is committed to reducing energy costs and environmental impacts of energy use while ensuring a safe, resilient, and reliable supply of energy.

[About the Energy Commission](#)
[CEC's 45th Anniversary Events](#)

energy.ca.gov

DIVISIONS

- Efficiency
- Energy Assessments
- Energy Research and Development
- Fuels and Transportation
- Renewable Energy
- Siting, Transmission, and Environmental Protection

LEADERSHIP



Gavin Newsom
California Governor



Wade Crowfoot
Secretary for Natural Resources



David Hochschild
Chair, California Energy Commission

TITLE 24, Part 6

California's Building Energy Efficiency Standards (aka the Energy Code) is updated every three years by the CEC. The process includes engagement with the public, industry experts, in-house expertise, and other stakeholders.





Big Picture Goals for the 2022 Code Updates

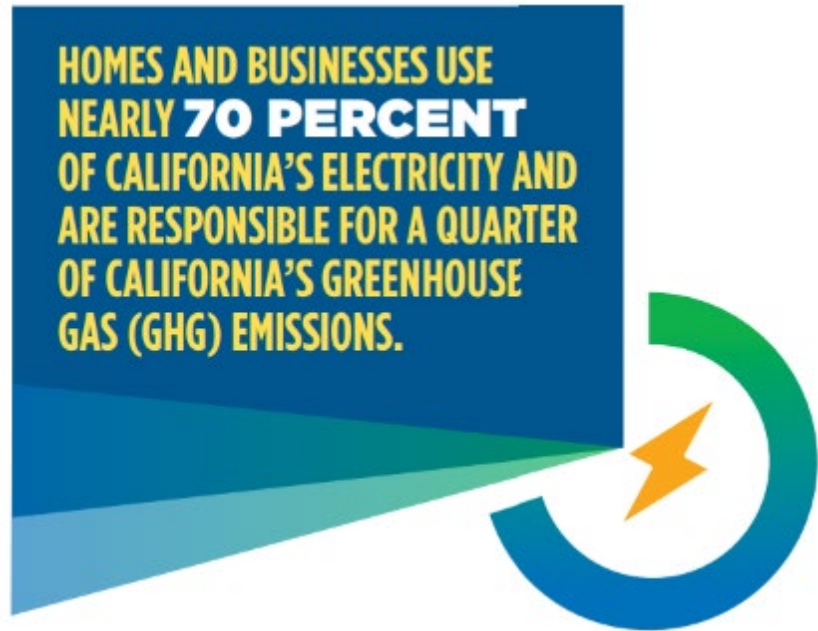

- Encourage heat pump technology for space and water heating
- Establish electric-ready requirements for single family homes
- Expand PV systems and battery storage standards
- Strengthen ventilation standards



Subchapter Reorganization

2019 Code

All Buildings -Sections 100 and 110

High-Rise Residential, Nonresidential,
Hotel/Motel -Sections 120, 130, 140,
and 141

Low-Rise Residential -Section 150.0-
150.2

2022 Code

All Buildings -Sections 100 and 110

Nonresidential, Hotel/Motel -Sections
120, 130, 140, and 141

Single-Family Residential -Section
150.0-150.2 (includes duplexes and
townhouses)

New Sections

Multifamily Buildings -Sections 160,
170, 180 (low and high rise)

The Energy Code –Three Compliance Terms

Mandatory Requirements

Energy efficiency measures that are applicable to all projects.

Prescriptive Component Package

Mandatory Requirements are applicable

Follow all the parts of the prescriptive package

Note: used to determine the Standard Design Building

Essentially a **checklist** approach

Performance Method

Mandatory Requirements are applicable

Other components or measures can be traded-off as long as the Proposed Design Building can be shown to be more energy efficiency than a similar sized Standard Design Building (baseline building)

Energy modeling approach

Performance Method

- **Existing Buildings, Additions and Alterations (E+A+A)**
The Energy Budget for additions and alterations is expressed in terms of **TDV**.
- **Time Dependent Valuation (TDV)** is the *cost* of energy-used metric –**EDR 2**
- **TDV** accounts for the energy used at the building site and consumed in producing and delivering energy to a site, including power generation, transmission and distribution losses, emissions abatement, production capacity, retail adjustment factors, and others.

Note:
EDR1 (Energy Design Rating - Source) Metric is only for NEW Construction as a proxy for carbon.



Excerpt from Compliance Form: CF1R-PRF-01-E

ENERGY USE SUMMARY

Energy Use	Standard Design Source Energy (EDR1) (kBtu/ft ² -yr)	Standard Design TDV Energy (EDR2) (kTDV/ft ² -yr)	Proposed Design Source Energy (EDR1) (kBtu/ft ² -yr)	Proposed Design TDV Energy (EDR2) (kTDV/ft ² -yr)	Compliance Margin (EDR1)	Compliance Margin (EDR2)
Space Heating	0	79.58	0	80.44	0	-0.86
Space Cooling	0	123.75	0	120.86	0	2.89
IAQ Ventilation	0	0	0	0	0	0
Water Heating	0	24.39	0	24.39	0	0
Self Utilization/Flexibility Credit						
Efficiency Compliance Total	0	227.72	0	225.69	0	2.03
Photovoltaics				0		
Battery						
Flexibility						
Indoor Lighting	0	7.33	0	7.33		
Appl. & Cooking	0	21.88	0	21.87		
Plug Loads	0	34.14	0	34.14		
Outdoor Lighting	0	1.75	0	1.75		
TOTAL COMPLIANCE	0	292.82	0	290.78		

Note:
EDR1 Source
Energy is '0'
i.e. 'not
applicable'

Building
Passes



Performance Method (Computer Modeling)

Performance Method:

- **Addition Alone** –The Standard (baseline) Design tracks closely with new construction.
- **Existing + Alteration Alone** –The Standard (baseline) Design is comprised of the existing building before alterations
- **Existing + Alteration + Addition (E+A+A)** –The Standard (baseline) Design is comprised of the existing building before alterations and a baseline addition.
- The ‘**existing**’ building may reflect default values or the *actual situation* if **HERS Verified Existing Conditions** is performed.

Common Trade-Off Strategies:

- If the Addition Alone does not comply, use E+A+A with added trade-offs.
- If added Alteration improvement credit is needed, get a HERS Verified Existing Conditions.



Example E+A+A Performance Results with Trade-Off

E+A+A Project –Traded-off exterior continuous insulation on the walls of an addition with a high efficiency water heater

ENERGY USE SUMMARY				
Energy Use (kTDV/ft ² -yr)	Standard Design	Proposed Design	Compliance Margin	Percent Improvement
Space Heating	8.9	10.05	-1.15	
Space Cooling	8.36	8.39	-0.03	
IAQ Ventilation	0	0	0	
Water Heating	18.45	17.06	1.39	7.5
Self Utilization/Flexibility Credit	n/a	0	0	n/a
Compliance Energy Total	35.71	35.5	0.21	0.6

Below
Standard

Above Standard

Complies





Additions and Alterations

Mandatory Measures

Prescriptive Addition

Prescriptive Alteration

Additions and Alterations –Section 150.2

- **Mandatory Measures** Section 150.0(a)-(u); most, but not all apply to Existing, Additions, and Alterations
- Reminder
- **Additions** have some minor updates, including a few new duct testing thresholds
- **Alterations** has new sections for ceiling insulation of vented attic assemblies, and IAQ Ventilation.

The Challenge of Existing Buildings

In addition to new buildings, the standards apply to substantial upgrades to existing homes and businesses.



At least 50 percent of single-family homes and nearly 60 percent of California's apartment complexes (about 14 million total residences) were built before the state's first energy standards.

Updating older buildings is critical to achieving the state's climate and clean energy goals.

Refers to specific Mandatory Measures (MM): 150.0(a)-(n), (p), and (q)

Section 150.2 specifically references the Mandatory Measures as detailed under Section 150.0 for new construction of single family homes.

Not listed, but referenced:

150.0 (o) – Ventilation and Indoor Air Quality (IAQ) is referenced throughout Section 150.2, but with nuanced exceptions.

Not Included :

150.0 (r) and (s)–Solar Ready and Battery Ready

150.0 (t), (u), (v)–Electric Ready for Heat Pumps, Cooktops, and Dryers

Listed Mandatory Measures:

150.0 (a) –Roof Insulation (Ceiling/Rafter)

150.0 (b) –Loose Fill Insulation

150.0 (c) –Wall Insulation

150.0 (d) –Raised-Floor Insulation

150.0 (e) –Decorative Fireplaces

150.0 (f) – Slab Edge Insulation

150.0 (g) –Vapor Retarder [Crawl Space]

150.0 (h) –Space Conditioning Equip

150.0 (i) –Thermostats

150.0 (j) –Pipe and Tank Insulation

150.0 (k) – Lighting

150.0 (l) – not used

150.0 (m) – Air-distribution [Ducts]

150.0 (n) – Water Heating

150.0 (p) – Pool Equip

150.0 (q) – Fenestration

Exceptions/Clarifications to Prescriptive Additions

- **Existing inaccessible piping** [*i.e. DHW, radiant, etc.*] shall not require insulation as defined under Section 150.0(j)1 [*Insulation for Piping and Tanks*]
- When **heating or cooling will be extended to an addition** from the existing system(s), the existing heating and cooling equipment need not comply with Part 6 [*Energy Code*].
- The heating **system capacity must be adequate** to meet the minimum requirements of CBC Section 1203.1
- When any length of **duct is extended from an existing duct system** to serve the addition, the existing duct system and the extended duct shall meet the applicable requirements specified in Section 150.2(b)1Di and 150.2(b)1Dii [*i.e. duct leakage and testing, etc.*]

CBC Excerpt:

1203.1 Equipment and Systems

Interior spaces intended for human occupancy shall be provided with active or passive space heating systems capable of maintaining an indoor temperature of not less than 68°F (20°C) at a point 3 feet (914 mm) above the floor on the design heating day.

Note:

Typically shown through ACCA or ASHRAE calculations

Clarify a common concern:

Solar Ready, Solar Panels (PV's) and Batteries, are *not* required for any alterations nor additions (nor triggered for an existing home.)



Space Heating for Additions

Space heating system. New or replacement space heating system serving an addition may be a **heat pump** or **gas heating** system.

Indoor Unit
Wall Mount



Example of a one-to-one mini-split heat pump with programable thermostat



Outdoor Unit /
Condenser



Requirements for Ventilation and Indoor Air Quality (IAQ)

ASHRAE 62.2 *continues* to be the ***basis*** for section 150.0(o)

- Quantity of outside air (OA) ventilation,
- Allowable methods of meeting the OA ventilation; and
- Field verification of IAQ system(s)

Updated or Added Language:

- Central Fan Integrated (CFI) Ventilation Systems
- Kitchen and Bathroom Exhaust
- Prescriptive Ventilation Duct Sizing
- Balanced Ventilation with Heat/Energy Recovery
- Required Testing of Ventilation System Air Flow

Note:

Outdoor Air (OA) are applicable to Additions over 1,000 square feet

Note:

Kitchen and Bathroom Exhaust applicable to all Additions

Additions –IAQ Ventilation

The following shall **not be required** to comply with the **150.0(o)1C, 1E, and 1F** whole-dwelling unit ventilation (**i.e. outside air ventilation with fan(s) or fan system**)

1. Additions of 1000 square feet or less
2. **Junior Accessory Dwelling Units (JADU)** that are additions to an existing building.

Local Mechanical Exhaust . Additions to existing buildings shall comply with all applicable requirements specified in **150.0(o)1G and 150.0(o)2**, (**i.e. mandatory exhaust for kitchen and bathroom, and field testing**)

Change from 2019 Code: Clarification that JADU's don't trigger IAQ indoor air quality ventilation calculations



Mechanical Exhaust –Kitchens and Bathrooms

Local Mechanical Exhaust shall be installed in each kitchen and bathroom. Systems shall be rated for airflow in accordance with ASHRAE 62.2 section 7.1.

- **Open (Nonenclosed) Kitchens** shall have demand controls and meet min ventilation flow or capture efficiency requirements
- **Enclosed Kitchens and Bathrooms** can use continuous ventilation systems that are part of Energy or Heat Recovery Balanced Ventilation (ERV/HRV) Systems
- All systems must have occupant **accessible ON-OFF** switches –and if part of IAQ ventilation system be label , "This switch controls the indoor air quality ventilation for the home. Leave it switch in the "on" position at all times unless the **outdoor air quality is very poor.**"

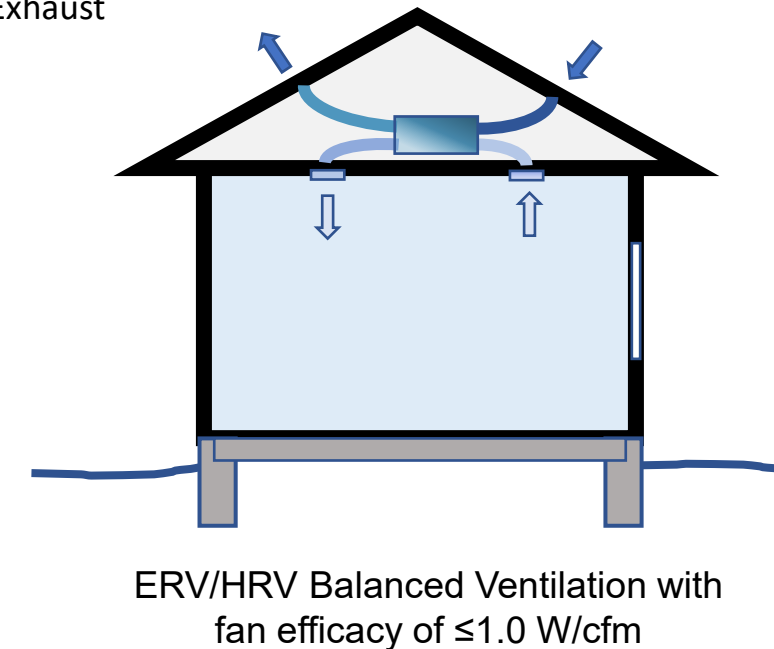
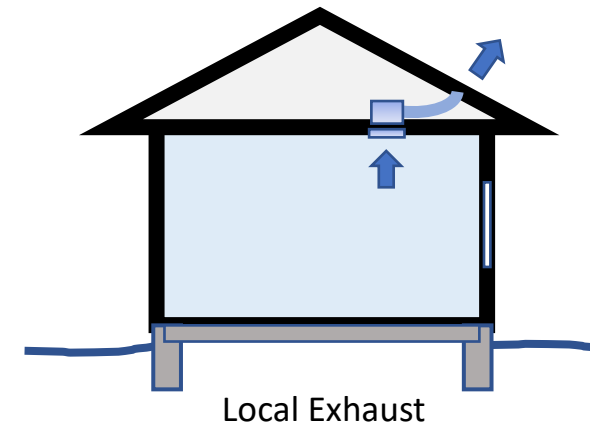

Kitchen –Range Hood

*Table 150.0-G Kitchen Range Hood Airflow Rates (cfm) and ASTM E3087 Capture Efficiency (CE) Ratings
According to Dwelling Unit Floor Area and Kitchen Range Fuel Type*

<u>Dwelling Unit Floor Area (ft²)</u>	<u>Hood Over Electric Range</u>	<u>Hood Over Natural Gas Range</u>
<u>>1500</u>	<u>50% CE or 110 cfm</u>	<u>70% CE or 180 cfm</u>
<u>>1000 - 1500</u>	<u>50% CE or 110 cfm</u>	<u>80% CE or 250 cfm</u>
<u>750 - 1000</u>	<u>55% CE or 130 cfm</u>	<u>85% CE or 280 cfm</u>
<u><750</u>	<u>65% CE or 160 cfm</u>	<u>85% CE or 280 cfm</u>

Note: In this illustration, a hood CE of 55% would only comply for the situations highlighted in blue.

Other exhaust fans, such as downflow, shall be 300 cfm or 5 ACH for enclosed kitchens

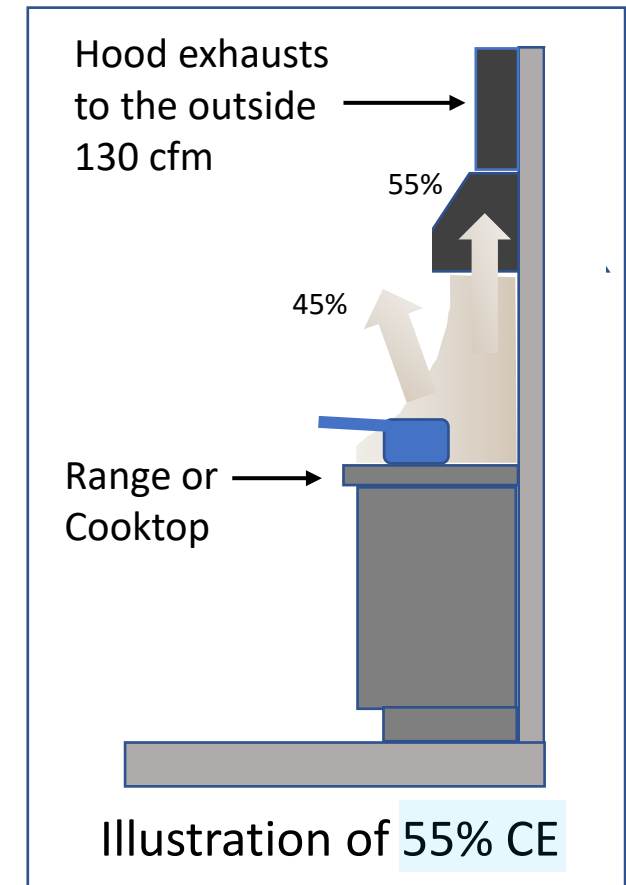

Mechanical Exhaust –Kitchen

- Installer to **field test** with air flow hood/grid, or
- Follow **Table 150.0-H Prescriptive** Ventilation System Duct Sizing (ASHRAE 62.2 Table 5-3)
 - Total duct length is ≤ 25 ft
 - Duct system has no more than 3 elbows
 - Duct system has exterior termination fitting

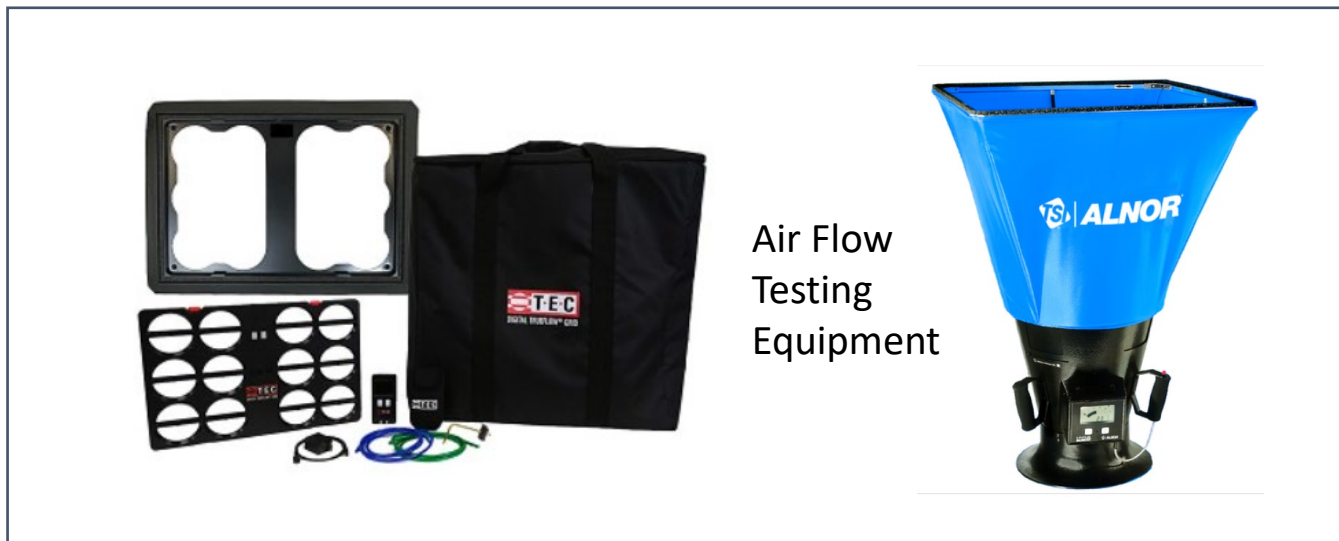

Key Take Aways:

- Applies to new or complete replacement of kitchen hood and ducting,
- Field test exhaust ducts or follow Prescriptive design,
- Kitchen range hood - HERS field verification required,
- **Exception:** Alteration that only replaces the hood and does not alter, add or replace the existing ductwork.

Alterations – Prescriptive Components

Section 150.2(b)1 Prescriptive Alterations:

- A. Add/New Fenestration
- B. Fenestration Replacement
- C. New/Replaced Space Conditioning System
- D. Altered Duct System
- E. Altered Space Conditioning System –Duct Sealing
- F. Altered Space Conditioning System –Cooling
- G. Altered Space Conditioning System –Heating
- H. Water Heating System –Replacement
- I. Roofs
- J. Ceilings –Vented Attics
- K. Lighting
- L. Mechanical IAQ Ventilation –New/Replaced
- M. Mechanical IAQ Ventilation –Altered
- N. Exterior Doors



Code Change: Sections J, L, M, and N are new

Alterations – Ventilation IAQ Systems

Mechanical Ventilation for Indoor Air Quality (IAQ)- Entirely **New** or Complete **Replacement** Ventilation Systems. Considered a complete replacement if **75% of duct** and associated materials are replaced. Duct system to comply with the **Mandatory Measures 150.0(o)** Ventilation and Indoor Air Quality.

Mechanical Ventilation for Indoor Air Quality - Altered Ventilation Systems. Altered ventilation system components or newly installed ventilation equipment serving the alteration shall comply with **Mandatory Measures 150.0(o)** Ventilation and Indoor Air Quality with qualifications...

- Fan Replacement
- Fan Alteration
- Air Filters
- Kitchen Exhaust
- Bathroom Exhaust
- Exhaust Fan Replacement

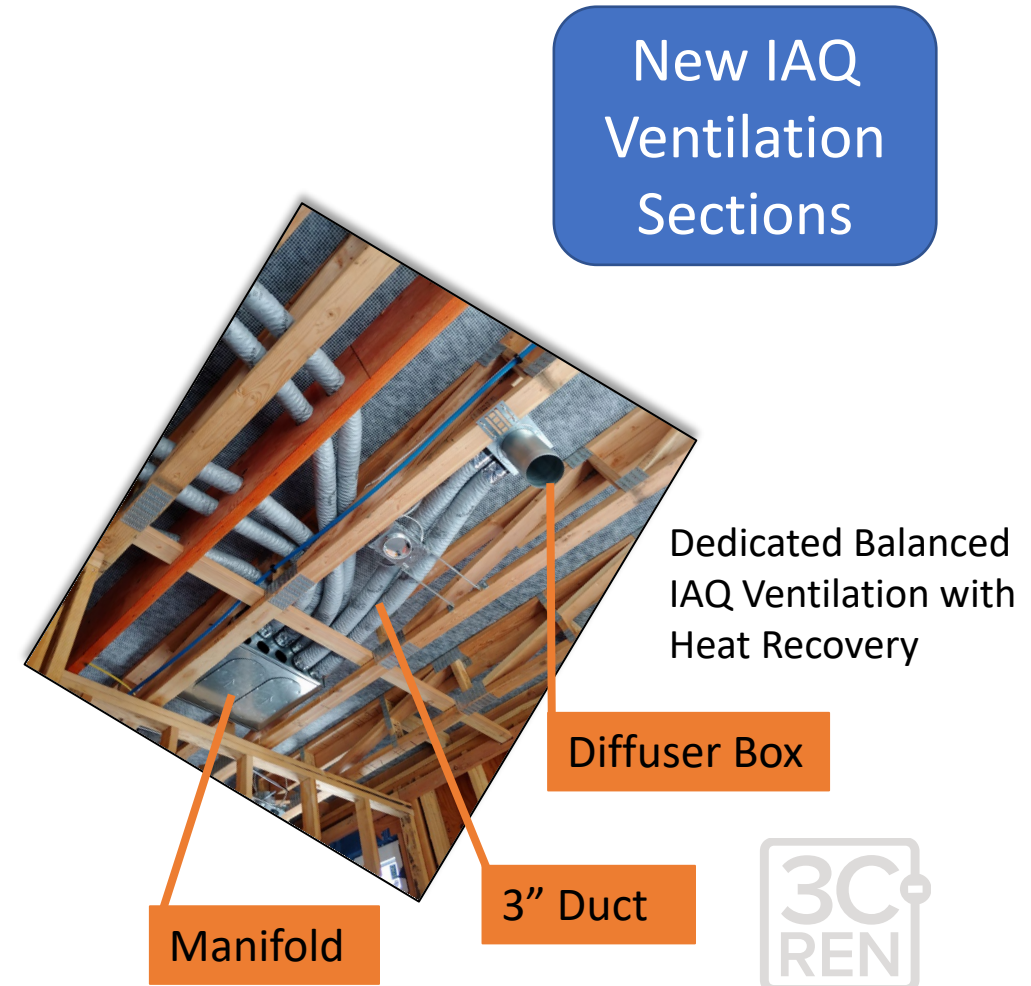

Alterations –Ducts

Updates:

- Ducts extended at least **25 ft** trigger this section (previously 40 ft)
- Duct leakage to test at **10%** or less (previously 15%)
- Duct leakage to the outside to test at **7%** or less (previously 10%)
- Duct Insulation increased to **R-8 for CZ 1, 2, 4, 8-10, 12, and 13** (previously R-6) Table 150.2-A

TABLE 150.2-A DUCT INSULATION R-VALUE

Climate Zone	3, 5-7	1, 2, 4, 8-16
Duct R-Value	R-6	R-8



R-8 Flex Duct

Unchanged: HVAC system located in garage –duct leakage testing is triggered.

Alterations Space Heating

Main Take-away: Clarification on where electric resistance heating can be used

Altered Space-Conditioning Heating System. Altered or replacement space-conditioning heating systems **shall not use electric resistance** as the primary heat source

EXCEPTION 1 to Section 150.2(b)1G: Non-ducted electric resistance space heating systems, if the existing space heating system is electric resistance.

EXCEPTION 2 to Section 150.2(b)1G: Ducted electric resistance space heating systems, if the existing space heating system is electric resistance and a ducted space cooling system is not being replaced or installed

EXCEPTION 3 to Section 150.2(b)1G: Electric resistance space heating systems, if the existing space heating system is electric resistance and the building is located in Climate Zones 7 or 15.

Typically not allowed...



Ductless Electric Wall Heater





Envelope

Wall Extensions, Alteration and Windows
Attic/Ceiling Alterations

Additions –Wall Extensions and Existing Framed Walls

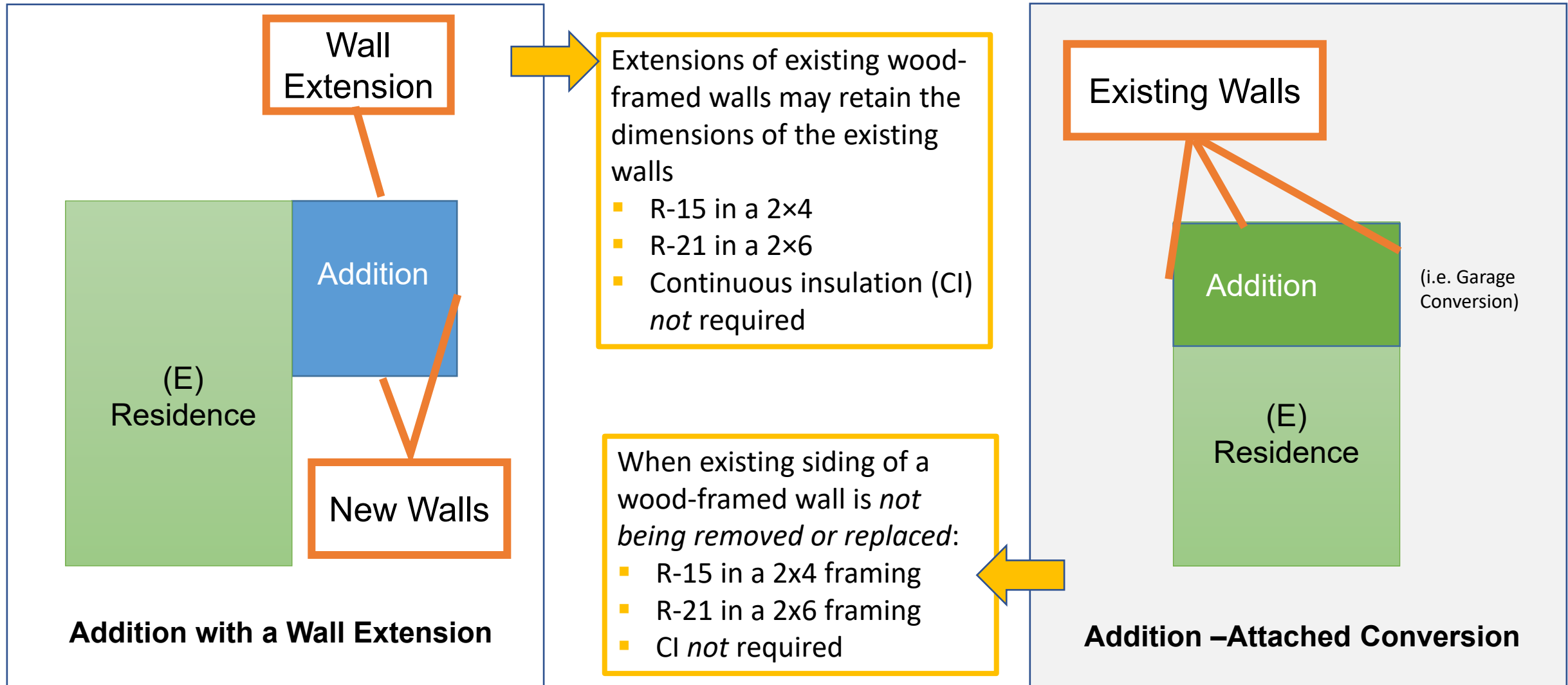

Wall Extension –Where a (N) Wall *aligns* with an (E) Wall

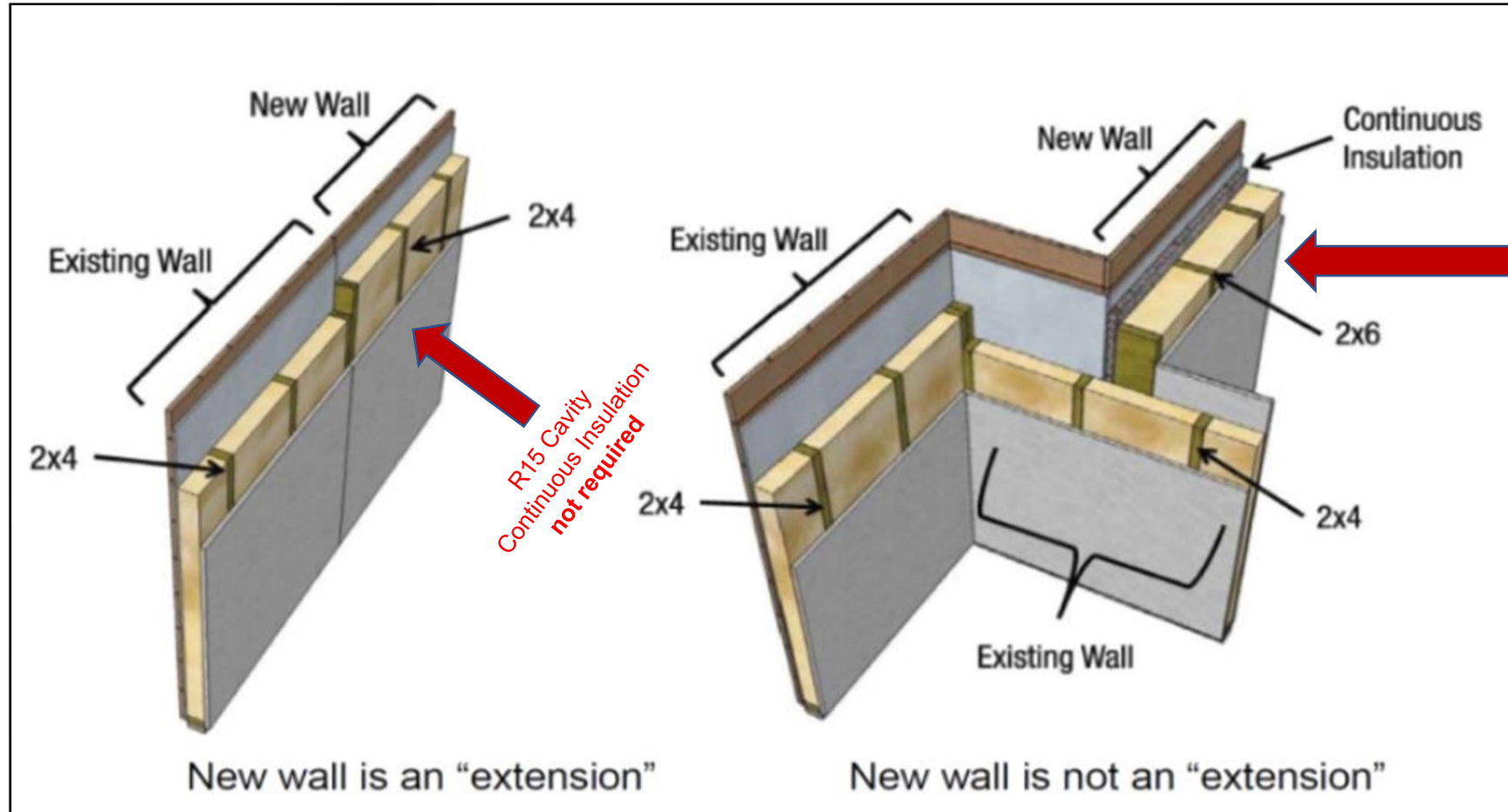

Image from CEC's BluePrint

Wall Extension: R-15 for 2x4 walls and R-21 for 2x6 walls



Alterations –Existing Walls and Window Replacements

Fenestration (Windows and Skylights)	U-factor All CZ	SHGC CZ 2, 4, 6-15	SHGC CZ 1, 3, 5 & 16
Window Replacement 75 sq ft or less	0.40	0.35	NR
Skylight Replacement	0.55	0.30	0.30
Window Replacement > 75 sq ft or New Additional Fenestration	0.30	0.23	NR
Total Glazing as a % of Floor Area	20%		
West Facing Glazing	5%		NR

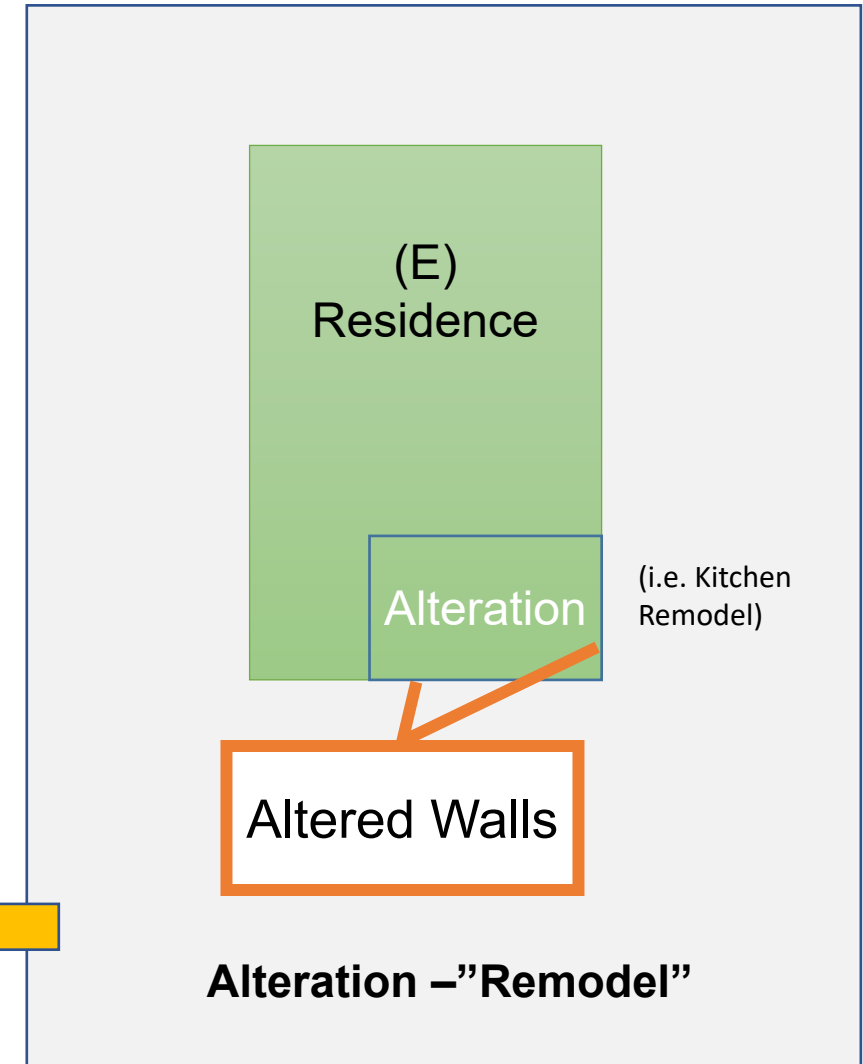

- Existing Walls being Altered:
- R-13 in a 2x4 framing
 - R-20 in a 2x6 framing



Wall Summary for Additions and Alterations

Excerpt from Table 28: Standard Design for Walls and Doors

Source: [California Energy Commission](https://www.energy.ca.gov/), ACM Manual

Proposed Design Exterior Wall Assembly Type	Addition	Altered
Framed & Non-Mass Exterior Walls	CZ 1-5, 8-16 = R-21+R-5 in 2x6 (U0.048) CZ 6-7 = R-15+R-4 in 2x4 (U-0.065)	R-13 in 2x4 R-20 in 2x6
Wood Framed Existing Walls where siding is not removed, or an extension of an existing wall	R-15 in 2x4 R-21 in 2x6	R-13 in 2x4 R-20 in 2x6
Framed Wall Adjacent to Unconditioned (e.g., Demising or Garage Wall)	R-15 in 2x4 R-21 in 2x6	R-13 in 2x4 R-20 in 2x6
Above Grade Mass Interior Insulated	CZ 1-15 = R-13 (0.077) CZ 16 = R-17 (0.059)	N/R Mandatory requirements have no insulation for mass walls
Below Grade Mass Interior Insulation	CZ 1-15 = R-13 (0.077) CZ 16 = R-15 (0.067)	N/R Mandatory requirements have no insulation for mass walls



Roof Deck in newly constructed Attic Systems with Ducts in the Attic

Applies to CZ 4 and 8-16:

- **New** Insulation either above or below the roof deck or a combination of the two
- Weighted average U-factor of roof **deck** cannot exceed 0.184 (Example, R-5.4 exterior continuous insulation)
- **Exceptions** when duct system is located within the **conditioned space**, i.e. below insulated ceiling

Image credit: CEC

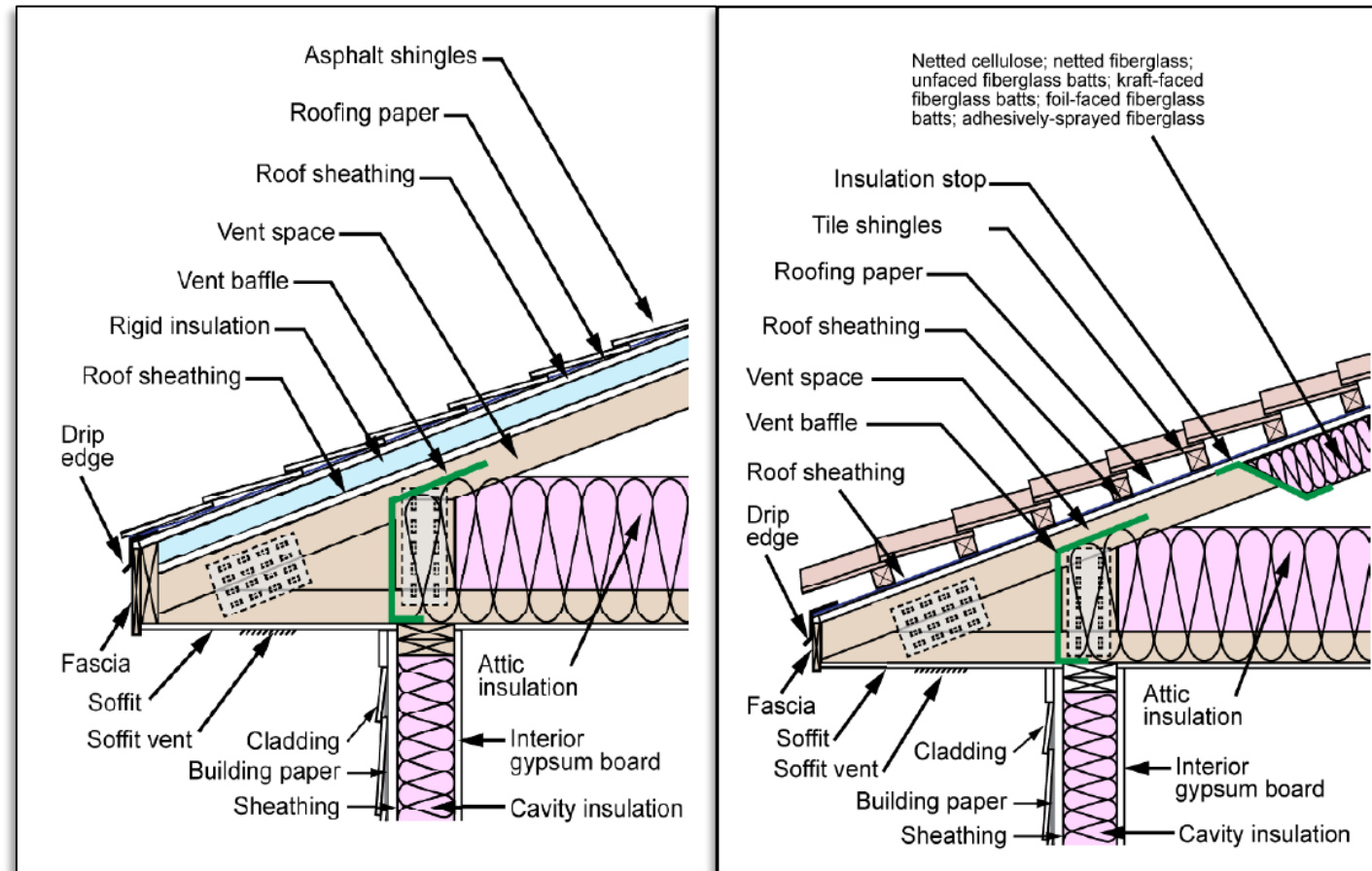

Reference: Section 410.116 of the CA Electric Code

410.116 Clearance and Installation

(A) Clearance

(1) Non-Type IC

A recessed luminaire that is not identified for contact with insulation shall have all recessed parts spaced not less than 13 mm ($1/2$ in.) from combustible materials. The points of support and the trim finishing off the openings in the ceiling, wall, or other finished surface shall be permitted to be in contact with combustible materials.

(2) Type IC

A recessed luminaire that is identified for contact with insulation, Type IC, shall be permitted to be in contact with combustible materials at recessed parts, points of support, and portions passing through or finishing off the opening in the building structure.

(B) Installation

Thermal insulation shall not be installed above a recessed luminaire or within 75 mm (3 in.) of the recessed luminaire's enclosure, wiring compartment, ballast, transformer, LED driver, or power supply unless the luminaire is identified as Type IC for insulation contact.

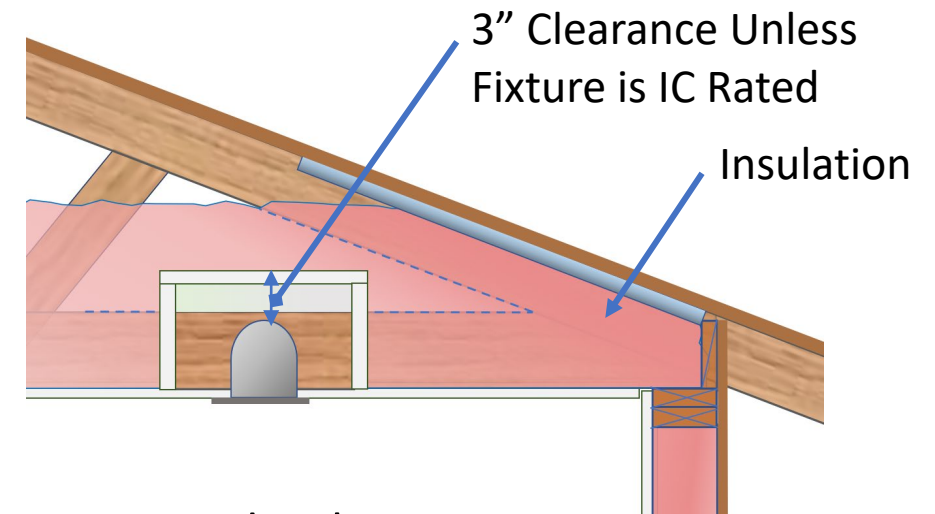

Recessed Light Fixture
with Fire-proof Cover



Alterations – Ceilings of Vented Attics

New
Section

Altered ceilings shall be insulated to R-49 in CZ 1-4, 6, 8-16

[not CZ 5 and 7]

- Except for CZ 1, 3, and 6 with existing R-19 insulation

In CZ 1-4 and 8-16 *[not CZ 5,6,or 7]* recessed downlights in the ceiling shall be covered with insulation to the same depth as the rest of the ceiling. Downlights not rated for insulation contact must be replaced or retrofitted with a fire-proof cover that allows for insulation to be installed directly over the cover

- Except CZ 1 -4 and 8 -10, existing R-19 insulation *[not CZ 11-16]*

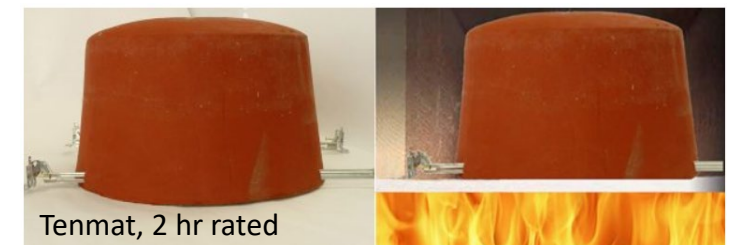
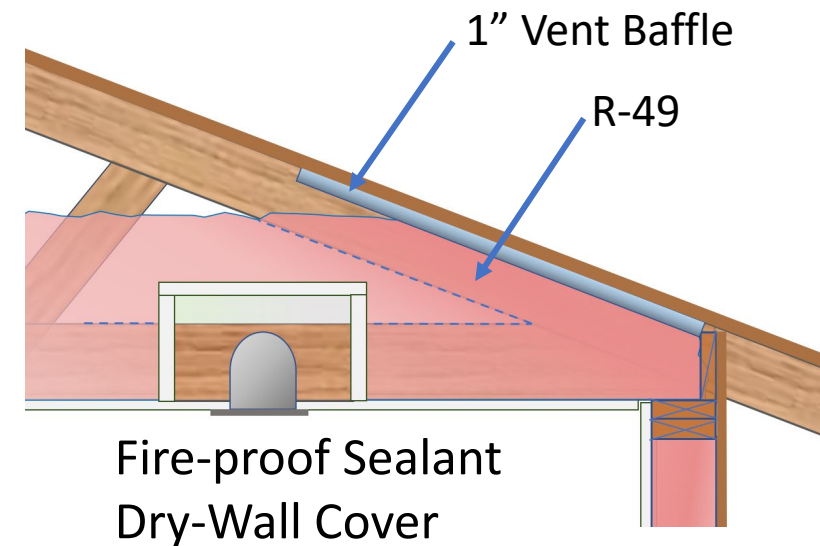

Tenmat, 2 hr rated

Manufactured Cover

Alterations – Ceilings of Vented Attics

New
Section

Altered ceilings must be air sealed in CZ 2, 4, 8-16 [not CZ 1,3, 5-7]

- Exception for existing R-19 insulation
- Except where combustion appliances are within the air boundary

Attic ventilation shall comply with the California Building Code requirements. Exception where

- existing R-38 existing insulation, asbestos, and knob and tube wiring
- the accessible spaces in the attic that are not large enough
- the attic space is shared with other dwellings that are not part of the alteration

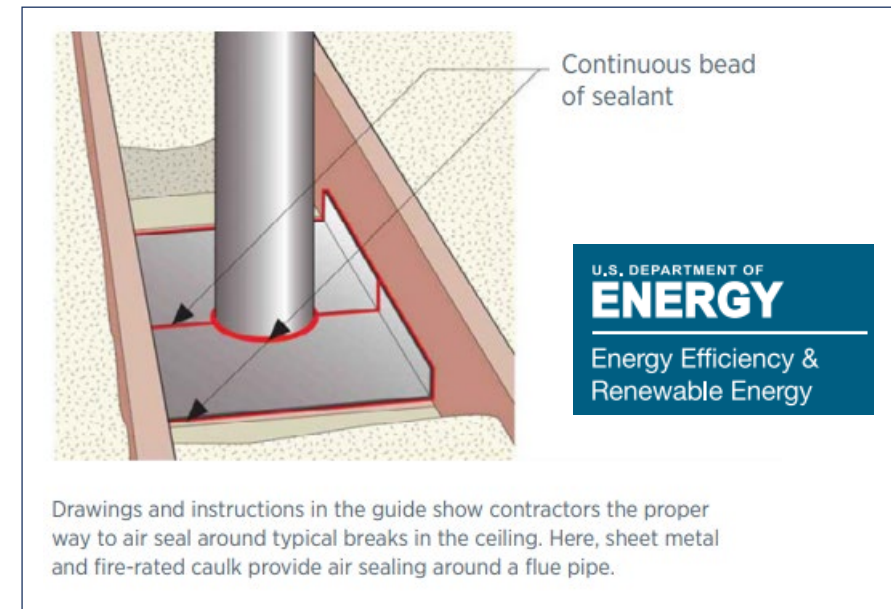

Additions –Roof and Ceiling

Additions that are **700 square feet or less** shall meet the requirements of Section 150.1(c) [i.e. Prescriptive Components], with the following modifications:

Roof and ceiling insulation in a ventilated attic shall meet one of the following requirements:

- a. In **Climate Zones 1, 2, 4, and 8 - 16**, achieve an overall assembly U-factor not exceeding 0.025. In wood framed assemblies, **R-38** or greater.
- b. In **Climate Zones 3, 5, 6, and 7**, achieve an overall assembly U-factor not exceeding 0.031. In wood framed assemblies, **R-30** or greater.

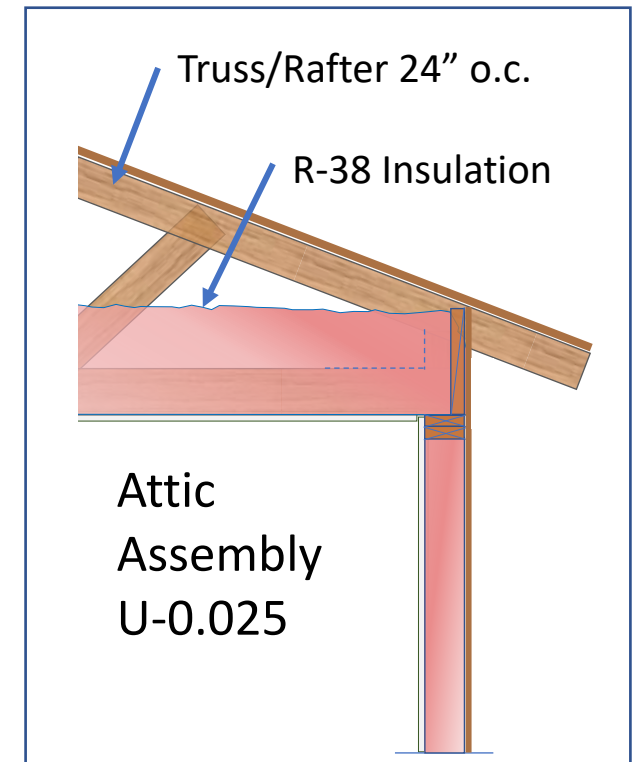

Change from 2019 Code: CZ's 2, 4, 8, 9 and 10 got “upgraded” to R-38





Domestic Water Heating Addition or Alteration

Additions –Second Water Heater

- A **single heat pump water heater** NEEA Tier 3 or higher
- A **gas or propane instantaneous water heater** with an input of 200 kBtu/h or smaller –no tank

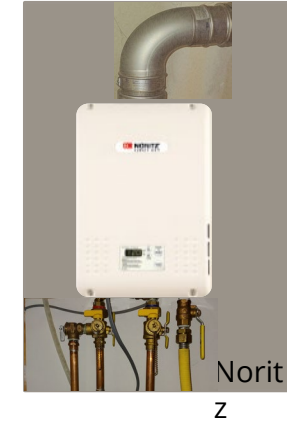

- For addition that are **500 sq ft or less**, an **instantaneous electric water heater** with ***point of use distribution*** as specified in RA4.4.5 is allowable



Additions –Second Water Heater

- **i. A single heat pump water heater.** The storage tank shall not be located outdoors and shall be placed on an incompressible, rigid insulated surface with a minimum thermal resistance of R-10. *The water heater shall be installed with a communication interface that meets either the requirements of 110.12(a) or has a ANSI/CTA-2045-B communication port*
- **ii. A single heat pump water heater** that meets the requirements of NEEA Advanced Water Heater Specification Tier 3 or higher
- **iii. A gas or propane instantaneous water** heater with an input of 200,000 Btu per hour or less and no storage tank
- **iv. For addition that are 500 square feet or less, an instantaneous electric water heater** with *point of use distribution* as specified in RA4.4.5

Change from 2019 Code: Electric On-Demand allowed with point of use distribution for additions 500 sf or less



Point of Use (POU) Electric - Addition 500 sf or less

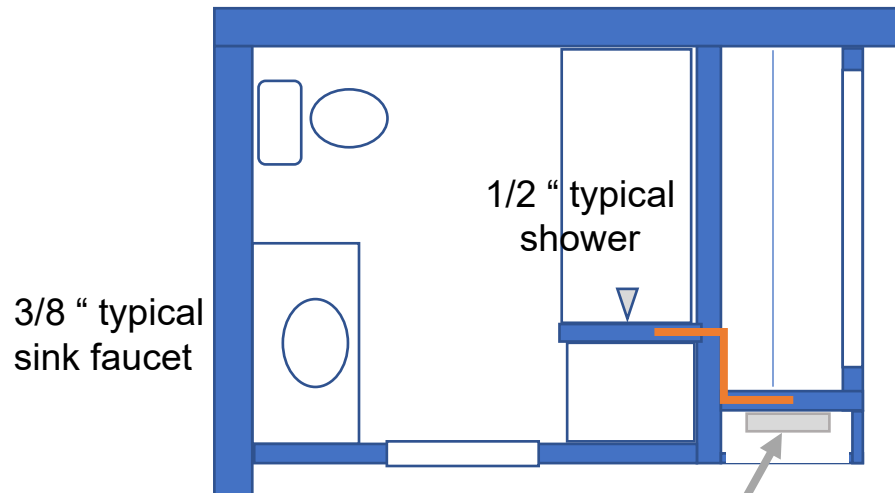

Instantaneous electric water heater with *point of use distribution*

Table 4.4.5

Size Nominal (Inch)	Length of Pipe (feet)
3/8"	15
1/2"	10
3/4"	5

Line size vs Length for each run

Other considerations: electric panel size and breaker(s); flush out /filter cleaning

Take most direct path with truck-branch line. If two pipe sizes are used in a single run, half the length of pipe shall be considered for each pipe size.

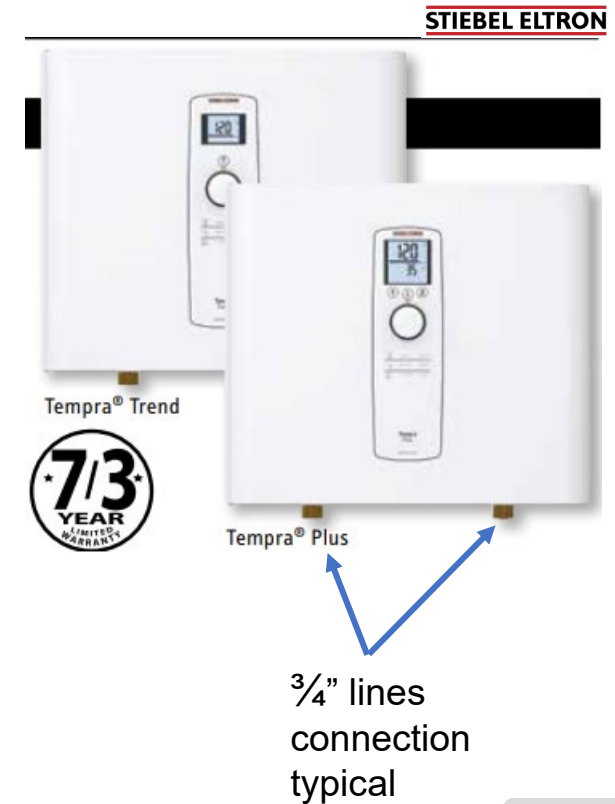

Building Dept Counter Card

CALIFORNIA ENERGY COMMISSION | EFFICIENCY DIVISION

Single-Family Residential Water Heater Alterations

2022 Title 24 Building Energy Efficiency Standards



Is the Existing Water Heater Electric Resistance?	What type can I install prescriptively?	What can I install under the performance approach?
NO	<ul style="list-style-type: none">• Natural gas or propane — tank or tankless (§150.2[b]1Hiii)• Heat pump — (§150.2[b]1Hiiib)¹• Heat pump — NEEA Tier 3 or higher (§150.2[b]1Hiiic)	Any type that uses no more energy than the standard design (gas or propane tankless; or heat pump, if proposed is electric). Must use CEC-approved compliance software (§150.2[b]2B)
YES	Consumer electric or heat pump — tank or tankless (§150.2[b]1Hiiid) ²	Any type that uses no more energy than the standard design (heat pump). Must use CEC-approved compliance software (§150.2[b]2B)

Note:
References Prescriptive Alterations Section 150.2(b)1H – see next slide

All existing accessible and newly installed piping must be insulated per §150.2(b)1Hi.

¹ **Storage tank cannot be outdoors and must be on rigid, incompressible surface insulated to R-10 or higher. Must have a communications interface meeting §110.12(a) requirements or have an ANSI/CTA-2045-B communication port.**

² **Per 10 CFR 430.2, consumer electric water heaters include:**

- **Electric storage or instantaneous water heaters with an input of 12 kilowatts or less.**
- **Heat pump-type units, with a maximum current rating of 24 amperes, at a maximum voltage of 250 volts, designed to transfer thermal energy to heat water, including all ancillary equipment (e.g., fans, storage tanks, pumps, or controls) necessary to its function.**

Prescriptive Alterations –Water Heater Replacement

Section 150.2(b)1H

i. **Pipe Insulation.** For newly installed and existing accessible piping, the insulation requirements of Section 150.0(j)1 shall be met.

ii. **Distribution System.** For recirculation distribution systems serving individual dwelling units, only Demand Recirculation Systems with manual on/off control as specified in the Reference Appendix RA4.4.9 shall be installed.

iii. **Water heating system.** The water heating system shall meet one of the following:

- a. A **natural gas or propane** water-heating system; or
- b. A **single heat pump water heater**. The storage tank shall not be located outdoors and be placed on an incompressible, rigid insulated surface with a minimum thermal resistance of R-10. The water heater shall be installed with a communication interface that meets either the requirements of Section 110.12(a) or has an ANSI/CTA-2045-B communication port; or
- c. A **single heat pump water heater** that meets the requirements of NEEA Advanced Water Heater Specification Tier 3 or higher; or
- d. If the existing water heater is an **electric resistance** water heater, a consumer electric water heater; or
- e. A water-heating system determined by the Executive Director to use no more energy than the one specified in Item a above; or if no natural gas is connected to the existing water heater location, a water-heating system determined by the executive director to use no more energy than the one specified in Item d above.





Electrification or Electric Ready



Electrification

Additions

Electric-Ready

- Water Heating:
 - Only if a new second LP/NG water heater is installed, then electric-ready for a future HPWH is triggered

Alterations

Electric Panel

- Electric Code
 - The panelboard shall meet the loads; triggered when the project increases the electric load beyond the existing panel capacity

New Construction

Otherwise, *NOT* REQUIRED

- Solar Photovoltaic (PV)
- Solar-Ready
- Battery-Ready
- 225 amp Busbar or Elec Panel
- Electric-Ready:
 - Heat Pump Space Conditionig
 - Cook Top
 - Clothes Dryer



Heat Pump Water Heater (HPWH) Ready

–triggered when installing a gas or propane water heater

- Dedicated space for future HPWH: **30" x 30" x 7'**
- All electrical components shall be installed in accordance with the ***California Electrical Code***.
- Specific electrical and plumbing requirements depend on **relative location** to the gas or propane water heater:
 - Use option A when χ is 3 ft or less
 - Use option B when χ is greater than 3 ft

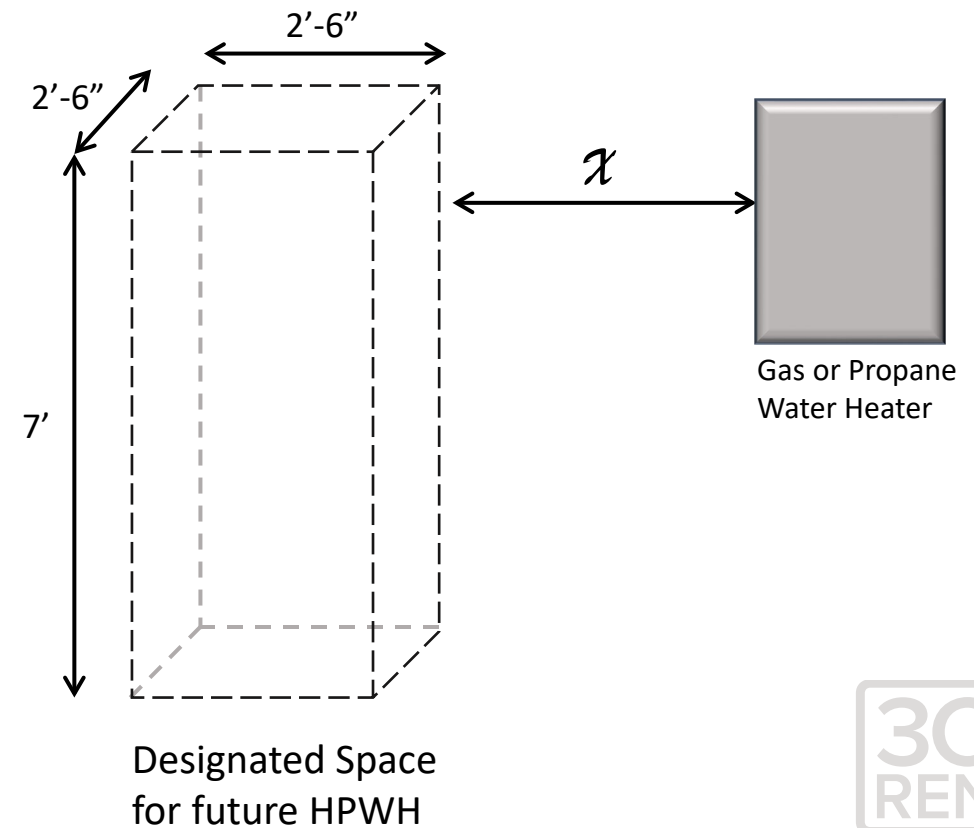

Pre-Wired for Future HPWH – Option A

A. If the designated space is **within 3 feet from the water heater**, then this space shall include the following:

- i. A dedicated **125 volt, 20 amp electrical receptacle** that is connected to the electric panel with a 120/240 volt 3 conductor, 10 AWG copper branch circuit, within 3 feet from the water heater and accessible to the water heater with no obstructions; and
- ii. Both ends of the unused **conductor shall be labeled** with the word “spare” and be electrically isolated; and
- iii. A reserved single pole **circuit breaker space in the electrical panel** adjacent to the circuit breaker for the branch circuit in A above and labeled with the words “Future 240V Use”; and
- iv. A **condensate drain** that is no more than 2 inches higher than the base of the installed water heater, and allows natural draining without pump assistance.

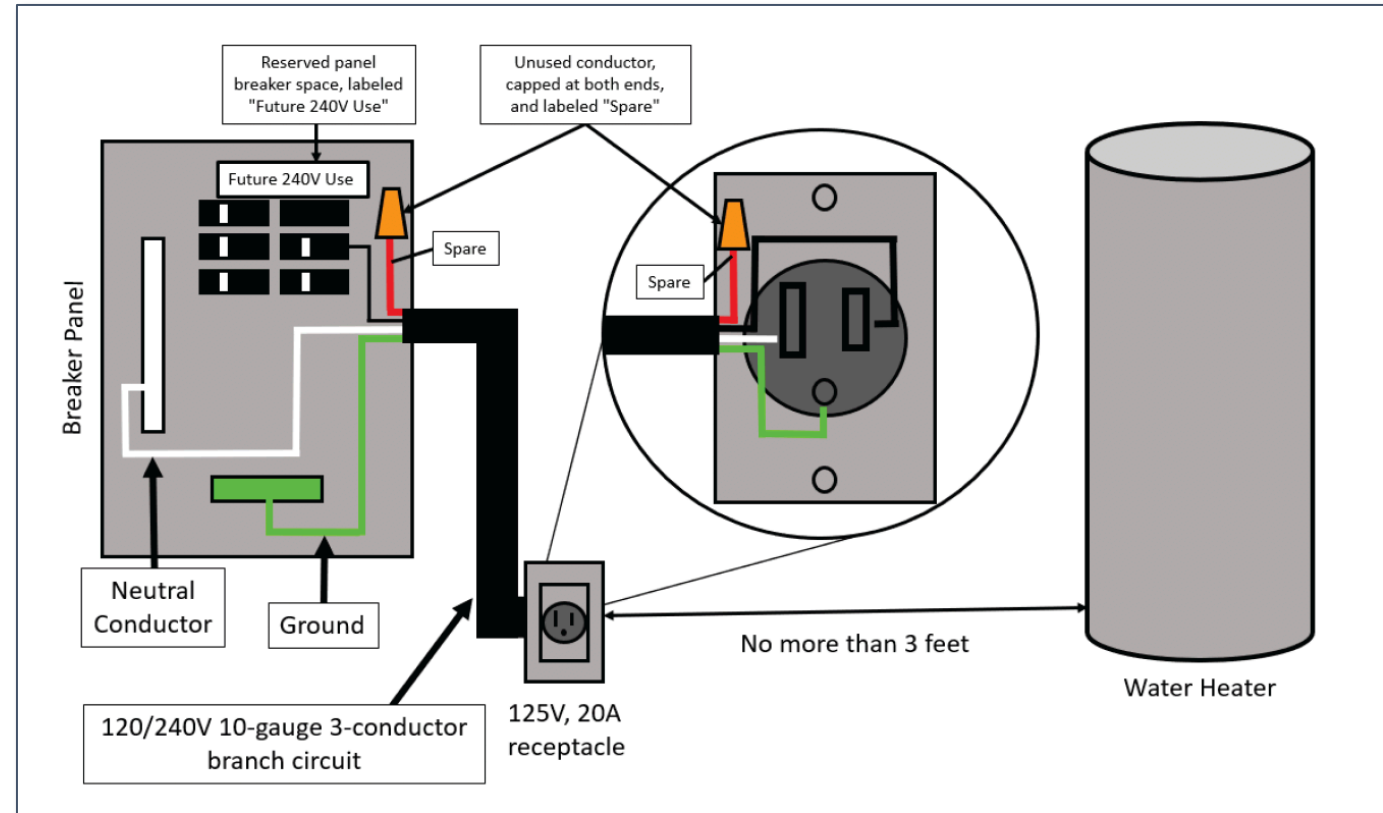

Credit: Blueprint, California Energy Commission, Issue 120 Apr/June 2020
<https://www.energy.ca.gov/programs-and-topics/programs/building-energy-efficiency-standards/online-resource-center>

Pre-Wired for Future HPWH – Option B

B. If the designated space is *more than 3 feet from the water heater*, then this space shall include the following:

- i. A dedicated **240 volt branch circuit** shall be installed within 3 feet from the designated space. The branch circuit shall be rated at **30 amps** minimum. The blank cover shall be identified as “**240V ready**”; and
- ii. The main electrical service panel shall have a reserved space to allow for the installation of a double pole circuit breaker for a future HPWH installation. The reserved space shall be permanently marked as “**For Future 240V use**”; and
- iii. Either a dedicated **cold water supply**, or the cold water supply shall pass through the designated HPWH location just before reaching the gas or propane water heater; and
- iv. The **hot water supply** pipe coming out of the gas or propane water heater shall be routed first through the designated HPWH location before serving any fixtures; and
- v. The hot and cold water piping at the designated HPWH location shall be **exposed and readily accessible** for future installation of an HPWH
- vi. A **condensate drain** that is no more than 2 inches higher than the base of the installed water heater, and allows natural draining without pump assistance.

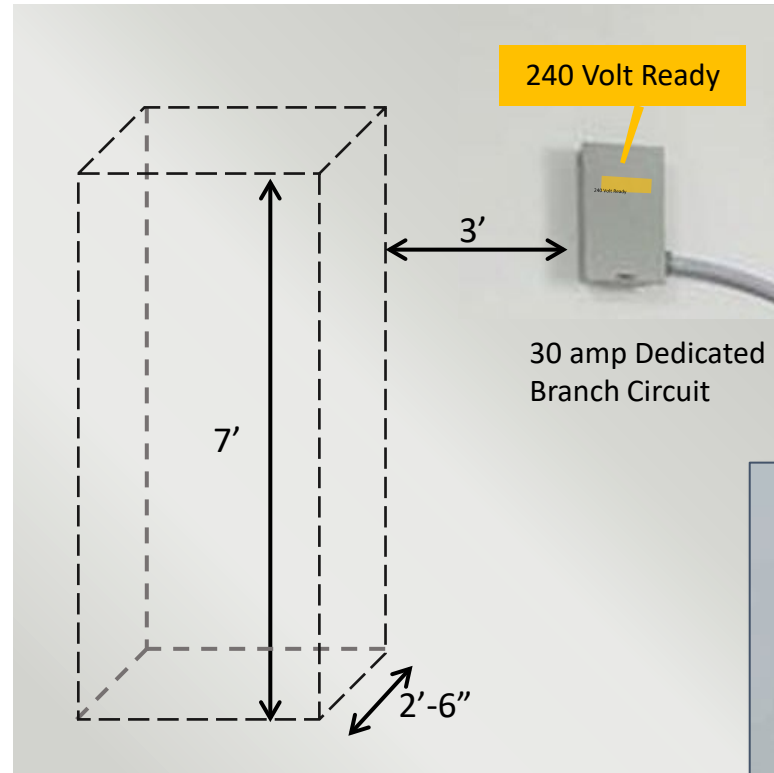

Designated Space for future HPWH

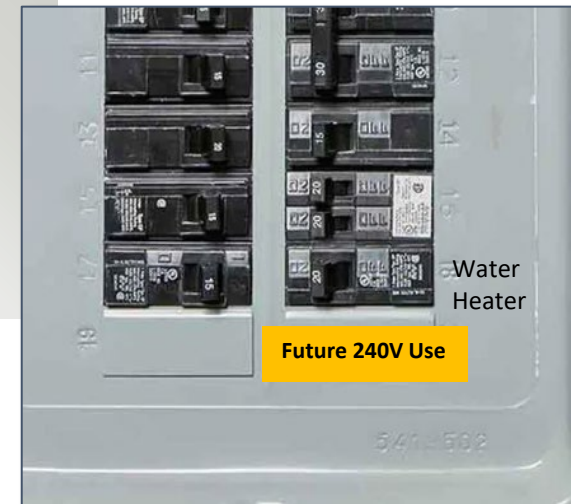

Main Panelboard

Condensate Drain –Required Under Both Option A and B

Additional Requirement:

- **Under Option A.v. and B.vi.:** A **condensate drain** that is no more than 2 inches higher than the base of the installed water heater, and allows natural draining without pump assistance.
- **Note:** The *condensate* is non-acidic. It is condensation from the surrounding air.

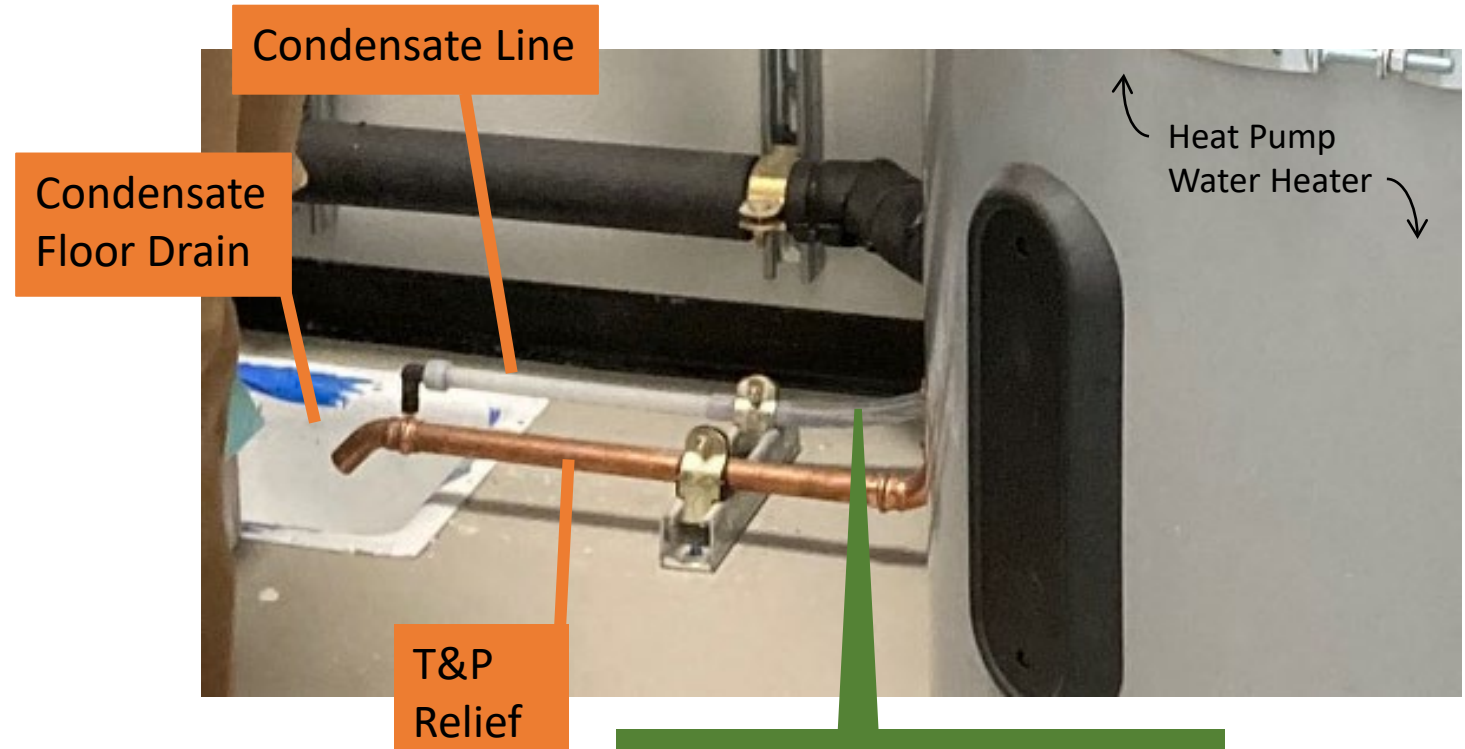

Tip: Use a portion of clear piping –easier to trouble shoot condensate drainage



Alignment with California Electric Code and Energy Code

ARTICLE 408 Switchboards, Switchgear, and Panelboards

Part I. General

408.2(A) California Energy Code Requirements for Panelboards in Single-Family Buildings [CEC]. In single-family residential buildings that include one or two dwellings, panelboards serving the individual dwelling unit shall be provided with circuit breaker spaces for heat pump water heaters, heat pump space heaters, electric cooktops and electric clothes dryers as specified in California Energy Code Section 150.0 (n), (t), (u) and (v).

Part III. Panelboards

408.30 General. All panelboards shall have a rating not less than the minimum feeder capacity required for the load calculated in accordance with Part III, IV, or V of Article 220, as applicable.

Section 150.0(n) Water Heating Systems

Excerpt:

All electrical components shall be installed in accordance with the *California Electrical Code*.

Similarly, Sections 150.0(t),(u), and (v) address electric ready for heat pump space heating, electric cook tops and electric dryers for new construction.

Article 220 details the manner and loads that shall be included in panel sizing.





HERS Verification – Opportunity for Credits

HERS Measures and HERS Verified Existing Conditions

- **Quality Insulation Installation (QII)** is a Prescriptive requirement (and Baseline) for New Construction and *Additions over 700 sq ft*
 - Or a *penalty*, if not done when using the Performance Method
- **Envelope Leakage Testing** – can be a credit, but may be very difficult
- **Kitchen Hood** – Exhaust Ventilation IAQ
- **Verified Existing Conditions** – HERS Credit Use if installing better insulation, better HVAC system, better water heater, etc. Can be use for Trade-Offs when using the Performance Method
- **Hot Water Distribution:** All Pipes Insulated, Point of Use, and Compact Plumbing, Recirculation, etc.
- Variable Capacity Heat Pump (**VCHP**) Credit –for space conditioning heat pumps

The screenshot displays the HERS software interface. It is divided into two main sections: 'HERS Measures' and 'HERS Verified Existing Conditions being Altered'. The 'HERS Measures' section includes three checked items: 'Quality Insulation Installation', 'Envelope Leakage Testing', and 'Project includes New or Replaced Kitchen Hoods'. Below these, the 'Status' is set to 'Altered'. 'Existing Leakage' and 'New Leakage' are both set to '5.0 ACH50'. The 'HERS Verified Existing Conditions being Altered' section lists eight items, all of which are checked: 'Wall/Door Construction', 'Roof Construction', 'Attic Construction', 'Floor Construction', 'Fenestration', 'HVAC', 'Domestic Hot Water', and 'Building Leakage'. Blue arrows from the text on the left point to the corresponding checkboxes in the software interface.



QII - Air Infiltration Sealing and Quality Insulation Installation

QII - AIR INFILTRATION SEALING – FRAMING STAGE
 CALIFORNIA ENERGY COMMISSION CEC-CF2R-ENV-21-H
SAMPLE FORM – NOT VALID FOR SUBMISSION TO BUILDING DEPARTMENTS

C. Walls Adjacent to Unconditioned Space

The responsible person's signature on this compliance document affirms that all applicable requirements in this table have been met.

01	All penetrations through the exterior wall air barrier are sealed to provide an airtight envelope to unconditioned spaces such as the outdoors, attic, garage, and crawlspace.
02	Exterior wall air barrier is sealed to the top plate and
03	All electrical boxes, including knockouts, that penetrate
04	All openings in the top and bottom plate, including for electrical and plumbing.
05	Exterior bottom plates (all stories) are sealed to the
06	All gaps around windows and doors are sealed. The
07	Rim joist gaps and openings are fully sealed.
08	Fan exhaust duct outlet/damper at the exterior wall
09	Knee walls have solid and sealed blocking at the bottom

E. Roof Air Barrier – Unvented Attics Adjacent to Conditioned Space
 The responsible person's signature on this compliance document affirms that all applicable requirements in this table have been met.

01	There is a continuous air barrier at the roof deck and
02	Chimneys and flues require sheet metal flashing at flashing is sealed to the surrounding framing.
03	All penetrations in the roof deck and gable ends for

INSULATION INSTALLATION
 CALIFORNIA ENERGY COMMISSION CEC-CF2R-ENV-03-E

H. Installed Insulation

Field	Field Description
01	Installed insulation R-values are the same or greater than listed on the CF1R.
02	No gaps or voids between the insulation and framing.
03	No gaps between the sides or ends of batt insulation.
04	Loose-fill insulation must be installed to the minimum installed weight per square foot (density) of the manufacturer's cut sheet for the proposed R-value.
05	Batt insulation is not compressed (no stuffing of the insulation into the cavity) and is installed to its full thickness.
06	Insulation is cut around obstructions such as electrical boxes.
07	Batt insulation is delaminated around all plumbing and electrical lines in ceilings, walls, and floors.
08	Band joists are insulated to the same R-value as the wall.
09	In all narrow cavities the insulation shall be cut to fit or filled with expanding foam.
10	Insulation was installed per manufacturer instructions.

The responsible person's signature on this compliance document affirms that all applicable requirements in this table have been met.

I. Wall Insulation



Exterior Bottom (Sill) Plates Sealed to Floor



Meeting QII – Air Infiltration Sealing at the Framing Stage will make –HERS Building /Enclosure Air Leakage Testing much easier!

VCHP Compliance Option –Shown on MCH-33-H –But Impacts Envelope Enclosure

Wall and Ceiling Penetrations for the Mechanical System Refrigerant, Condensate, and Communication Lines need to be Air Sealed.

CERTIFICATE OF VERIFICATION		CF3R-MCH-33-H		
Variable Capacity Heat Pump Compliance Credit		(Page 2 of 4)		
C. Verification: Ducted Indoor Units Located Entirely in Directly Conditioned Space - RA3.1.4.3.8				
This section does not apply to this project.				
D. Verification: Ductless Indoor Units Located Entirely in Directly Conditioned Space - RA3.1.4.1.8				
A visual inspection shall confirm that ductless indoor units are located entirely in conditioned space in accordance with the procedures of SC3.1.4.1.8.				
01	02	03		
Indoor Unit Name or Description of Area Served	Indoor Unit Installation Location Verification	Compliance Statement		
Living Unit	Indoor unit mounted entirely on the surface of walls, ceilings, or floors	Complies		
Right Bed Unit	Indoor unit mounted entirely on the surface of walls, ceilings, or floors	Complies		
Left Bed Unit	Indoor unit mounted entirely on the surface of walls, ceilings, or floors	Complies		
Notes:				
E. Verification: Wall Mounted Thermostats - SC3.4.5				
Field verification according to the procedure in SC3.4.5 shall confirm that VCHP space conditioning zones that are greater than 150 ft ² , are controlled by a permanently installed wall-mounted thermostat.				
01	02	03	04	05
Indoor Unit Name or Description of Area Served	Is a Wall-mounted Thermostat Installed in the Zone Served by the Indoor Unit?	Does the Thermostat Control the Zone's Indoor Unit?	Is the Thermostat Mounted Permanently to the Wall?	Compliance Statement
Living Unit	Yes	Yes	Yes	Complies
Right Bed Unit	Yes	Yes	Yes	Complies
Left Bed Unit	Yes	Yes	Yes	Complies
Notes:				

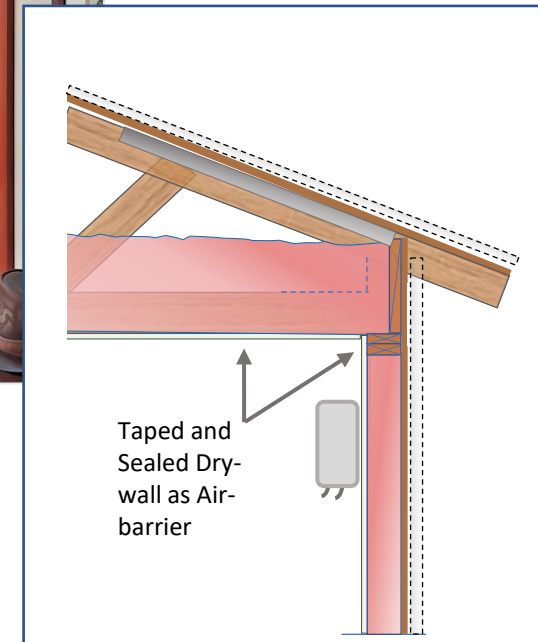

Vented Attic with a Continuous Air and Thermal Boundary

VCHP Compliance Option – Shown on MCH-33-H – But Impacts Envelope Enclosure

Indoor units shall be installed within the air and thermal boundaries

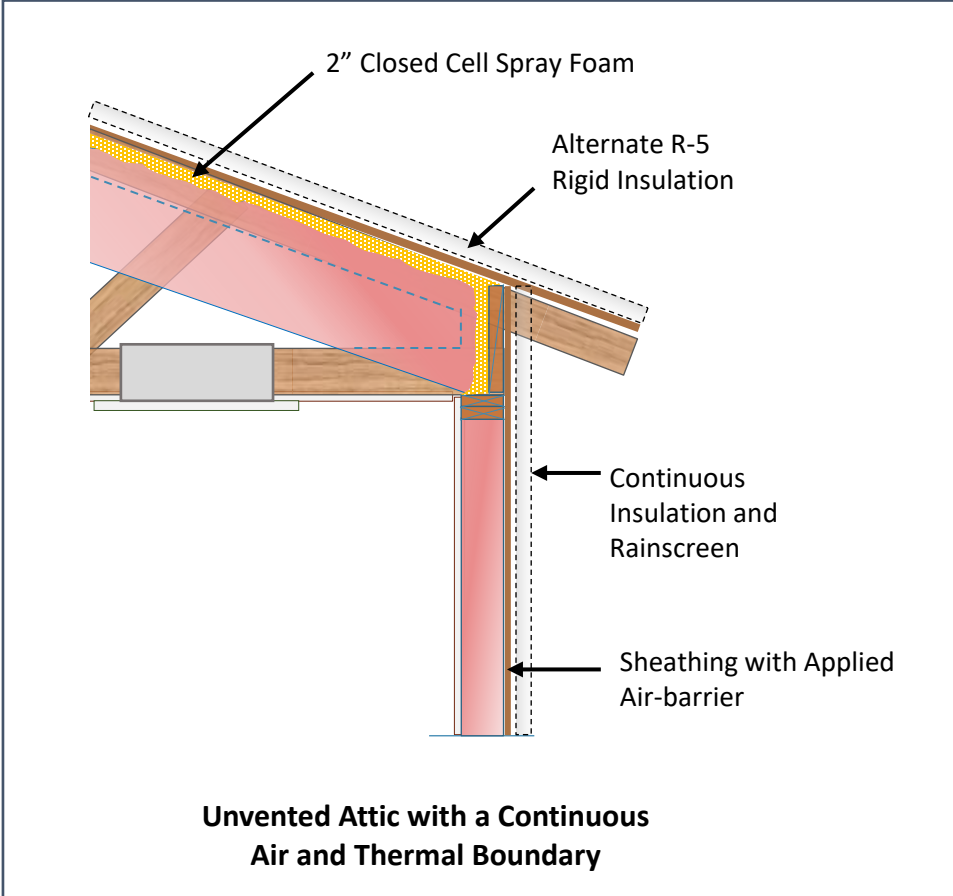

Ductless Recessed-Ceiling

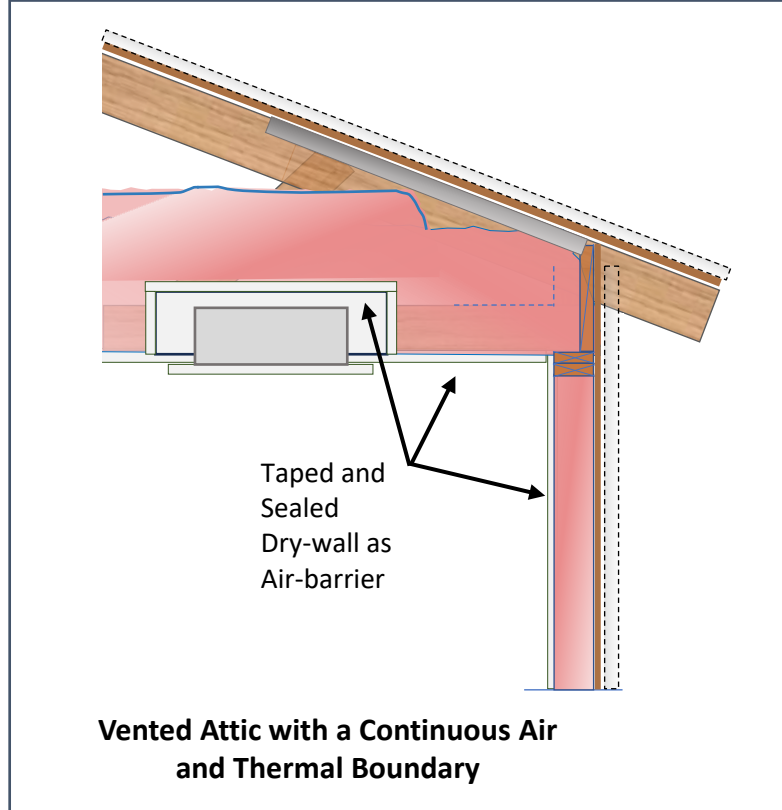

CF3R-EXC-20-H –Existing Conditions

- HERS Rater verifies the status of a home's existing conditions through visual inspection and field testing, when warranted.
- The visual inspection and test results are uploaded to a HERS Registry and shared with the energy consultant and designer.
- Design team can make informed decisions for best energy performance and potential credits/trade-offs.
- If HERS Existing Conditions are not used, default values per Table 150.2-D are assumed.



CALIFORNIA ENERGY COMMISSION

EXISTING CONDITIONS FOR RESIDENTIAL ALTERATIONS

CEC-CF3R-EXC-20-H

SAMPLE FORM – NOT VALID FOR SUBMISSION TO BUILDING DEPARTMENTS

CERTIFICATE OF VERIFICATION

Note: This table completed by HERS Registry.

Project Name:	CF1R-PRF Calculation Date/Time:
CF1R-PRF Calculation Description:	CF1R-PRF Input File Name:

A. General Information

01	Project Name	
02	Calculation Description	
03	Project Location	
04	CA City	05 Standard Version
06	Zip Code	07 Software Version
08	Climate Zone	09 Front Orientation (deg/Cardinal)
10	Total Building Volume (ft ³)	11 Number of Dwelling Units
12	Project Scope	13 Number of Bedrooms
14	New Conditioned Floor Area(ft ²)	15 Number of Stories
16	Existing Conditioned Floor Area (ft ²)	17 Fenestration Average U-factor
18	Total Conditioned Floor Area (ft ²)	19 Glazing Percentage (%)

Registration Number:
CA Building Energy Efficiency Standards - 2022 Residential Compliance

Registration Date/Time:

Hire your HERS Rater during design stage.



Water Heating System –Alterations and Additions

Table 35: Standard Design for Water Heater Systems

Proposed Design Water Heating System Type	Addition (adding water heater)	Altered	Verified Altered
Single-Family Residential Buildings	Prescriptive water heating system per Section 2.10.4 Addition-Along Approach	Proposed fuel type, proposed tank type, mandatory requirements (with no solar)	Existing water heater type(s), efficiency, distribution system.

Alteration: (E+A+A) a replaced water heater can be a valuable credit

Source: [California Energy Commission](#)

Standard Design for Additions:

The domestic water heating system is a natural gas tankless (or propane if natural gas is not available) if the proposed design has a gas water heating system. The standard design water heating system is a heat pump water heater if the proposed design has an electric water heating system. For additions 500 square feet or less, the standard design is an instantaneous electric water heater if the proposed design is an instantaneous electric water heater, or the standard design is an electric consumer storage water heater less than or equal to 20 gallons if the proposed design is an electric consumer storage water heater less than or equal to 2'0 gallons.

Additions: 2nd water heater is not 'penalized', but it is not necessarily a 'credit' either



Insulation for Piping

Field Verification, HERS Credit:

- Under the Performance Method - HERS Credit is available for visual inspection to ensure appropriate insulation levels were installed, and other details such as all corners and tees are properly insulated, etc.
- **All hot water piping shall be insulated per CA Plumbing Code 609.11**
- Exception: Piping surrounded with a minimum of 1 inch of wall insulation, 2 inches of crawl space insulation, or 4 inches of attic insulation, shall not be required to have pipe insulation.

Reminder: Exception to 150.2 Additions and Alterations
Existing piping that is inaccessible



Heat Pump Water Heater

Questions about Title 24?

3C-REN offers a *free* Code Coach Service



Online:
3c-ren.org/codes

Call:
805.781.1201

Energy Code Coaches are local experts who can help answer your Title 24 questions. Coaches have decades of experience in green building and energy efficiency improvements. They can provide citations and offer advice for your project to help your plans and forms earn approval the first time.

Closing

- Continuing Education Units Available
 - Contact shuskey@co.slo.ca.us for AIA and ICC LUs
- Coming to Your Inbox Soon!
 - Slides, Recording, & Survey – Please Take It and Help Us Out!
- Upcoming Courses:
 - March 14th - [Using Building Science to Design and Build High Performance Homes – Class 2: High Performance Fundamentals Series](#)
 - March 19th - [Tiny Homes and ADUs for Homeowners](#) (In Person at Waterman Village in San Luis Obispo)
 - March 20th - [Energy Code Compliance: Using HERS Measures \(Part 2\)](#)
 - March 21st - [Detailing for High Performance Roofs and Walls](#)
 - March 28th - [Multi-Family Domestic Hot Water](#)
- Visit www.3c-ren.org/events for our full catalog of trainings.





Thank you!

For more info:
3c-ren.org

For questions:
info@3c-ren.org



TRI-COUNTY REGIONAL ENERGY NETWORK
SAN LUIS OBISPO • SANTA BARBARA • VENTURA